



**EVT
SCOOTERS**
SERVICE MANUAL
EVT-168



BEV BRAVO
ELECTRIC VEHICLES

Table of Contents

- | | |
|-------------------------------|-----------------------------------|
| 1. Front Cover | 23. Rear Shock Absorber |
| 2. Seat | 24. Rear Caliper |
| 3. Center Cover | 25. Brake Master Cylinder |
| 4. Left Side Cover | 26. Brake Hose |
| 5. Right Side Cover | 27. Brake Fluid |
| 6. Footrest Board | 28. Brake Pad |
| 7. Tail Bracket | 29. Direct Driven Hub-Motor |
| 8. Rear Body Cover | 30. Brake Disk |
| 9. Lower Cover | 31. Rear Fork |
| 10. Fairing | 32. Front Shock Absorber |
| 11. Front Fender | 33. Head Lamp |
| 12. Rear Fender | 34. Front Direction Lamp |
| 13. Head Lamp Bulb | 35. Current Meter and Speedometer |
| 14. Front Direction Lamp Bulb | 36. Left Handle Switch |
| 15. Tail Lamp Bulb | 37. Right Handle Switch |
| 16. Rear Direction Lamp Bulb | 38. Tail Lamp Assembly |
| 17. Main Switch | 39. Front Brake Cable |
| 18. Seat Lock Assembly | 40. Throttle Cable |
| 19. Horn | 41. Handle |
| 20. Flasher Relay | 42. Steering Bracket |
| 21. DC to DC Converter | 43. Front Fork and Ball Race |
| 22. Controller | 44. Part Summary |

Front Cover

Tools Required: Phillips screwdriver

Time: Allow 10 minutes for procedure

1. Release the screw on the front cover.



2. Release four screws on the back of the front cover.

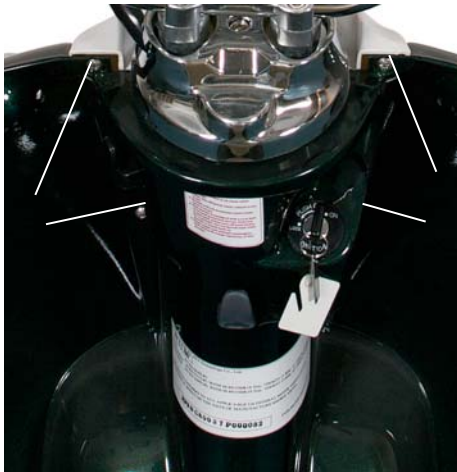

3. Remove the front cover.

4. Follow with the reversed steps to restore.

Seat

Tools Required: T-bend socket wrench, 10mm

Time: Allow 10 minutes for procedure

1. Release two nuts on the seat.



2. Remove the seat.

3. Follow with the reversed steps to restore.



Center Cover

Tools Required: T-bend socket wrench, 8mm

Time: Allow 10 minutes for procedure

1. Release the screw on the center cover.



2. Remove the center cover.

3. Follow with the reversed steps to restore.



Left Side Cover

Tools Required: Phillips screwdriver

Time: Allow 10 minutes for procedure

1. Remove the center cover.
2. Release four screws on the left side cover.



4

3. Remove the left side cover.
4. Follow with the reversed steps to restore.



Right Side Cover

Tools Required: Phillips screwdriver

Time: Allow 10 minutes for procedure

1. Release the screw on the cover.



2. Remove the cover.
3. Release four screws on the right side cover.
4. Remove the right side cover.

Footrest Board

Tools Required: T-bend socket wrench, 10mm

Time: Allow 10 minutes for procedure

1. Release four screws on the footrest board.



6

2. Remove the footrest board.
3. Follow with the reversed steps to restore.

Tail Bracket

Tools Required: Y-bend socket wrench, 10mm; hex-key wrench, 6mm

Time: Allow 10 minutes for procedure

1. Release the screw on the tail bracket.



2. Release two nuts on the tail bracket.
3. Remove the tail bracket.
4. Follow with the reversed steps to restore.

Rear Body Cover

Tools Required: Phillips screwdriver

Time: Allow 10 minutes for procedure

1. Release four screws on the rear cover.



2. Remove the plastic cover on the seat lock.
3. Release the 6-pin connector and 2-pin connectors.
4. Remove the rear cover.
5. Follow with the reversed steps to restore.

Lower Cover

Tools Required: Phillips screwdriver

Time: Allow 10 minutes for procedure

1. Remove the footrest board and release the screw on the front of the lower cover.



2. Remove the lower cover.
3. Follow with the reversed steps to restore.

Fairing

Tools Required: T-bend socket wrench, 8mm

Time: Allow 10 minutes for procedure

1. Remove the footrest board and the hanger on the back of the fairing.



10

2. Remove the fairing.
3. Follow with the reversed steps to restore.

Front Fender

Tools Required: Phillips screwdriver

Time: Allow 10 minutes for procedure

1. Release three screws on the rear front fender.



2. Release the screw on the top of the rear front fender and remove.



3. Follow with the reversed steps to restore.

Rear Fender

Tools Required: Phillips screwdriver
Time: Allow 10 minutes for procedure

1. Remove the right and left side covers and release two screws on the rear fender.

12



2. Remove the rear fender.
3. Follow with the reversed steps to restore.



Head Lamp Bulb

Tools Required: Phillips screwdriver

Time: Allow 10 minutes for procedure

1. Release the screw on the head lamp ring.



2. Release the head lamp ring.
3. Release the spring on the bulb base.
4. Remove the bulb base and replace the bulb.
5. Follow with the reversed steps to restore.

Front Direction Lamp Bulb

Tools Required: Phillips screwdriver

Time: Allow 10 minutes for procedure

1. Release the screw on the base of the direction lamp.



- 14 2. Release the screw on the cover of the bulb.



3. Replace the bulb and follow the reversed steps to restore.

Tail Lamp Bulb

Tools Required: Phillips screwdriver

Time: Allow 10 minutes for procedure

1. Release two screws on the tail lamp cover and remove.



2. Replace the light bulb.
3. Follow the reversed steps to restore.

Rear Direction Lamp Bulb

Tools Required: Phillips screwdriver

Time: Allow 10 minutes for procedure

1. Release the screw on the base of the direction lamp.



2. Remove the cover of the direction lamp.
3. Replace the bulb and follow the reversed steps to restore.

Main Switch

Tools Required: T-bend socket wrench, 10mm

Time: Allow 10 minutes for procedure

1. Remove front covers.
2. Release the 4-pin connector.

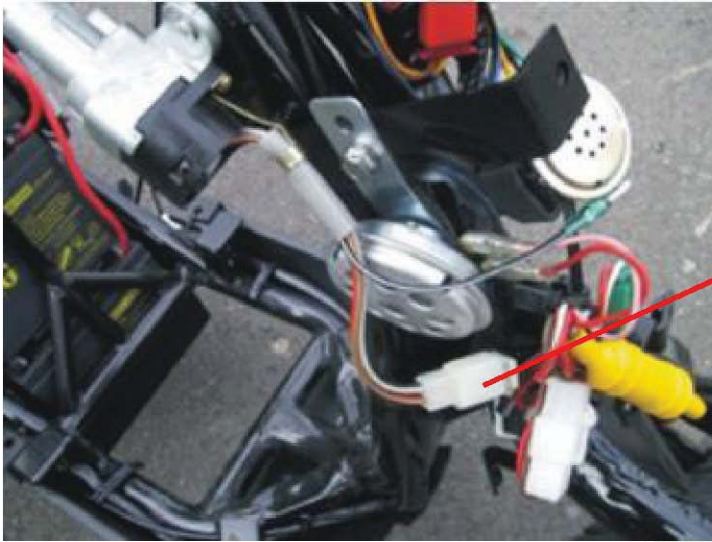

3. Release two screws on the main switch and remove the key switch.

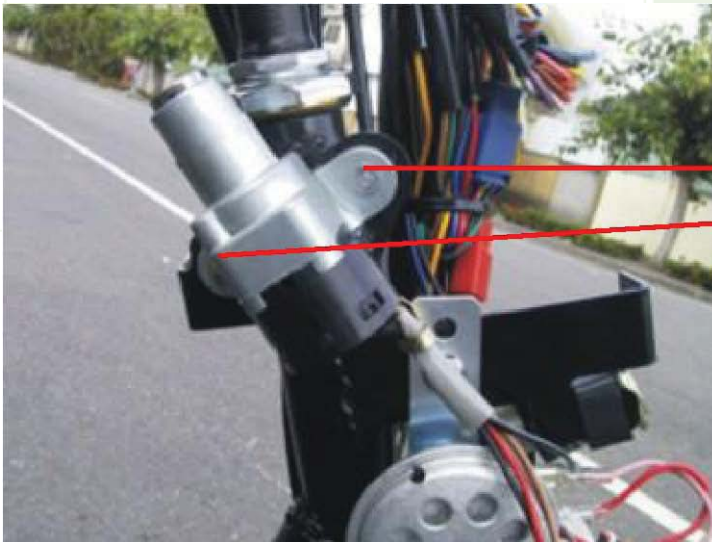

4. Follow with the reversed steps to restore.

Seat Lock Assembly

Tools Required: Phillips screwdriver

Time: Allow 10 minutes for procedure

1. Remove the rear body cover.
2. Remove the seat box rim.
3. Release two screws on the seat lock.



18

4. Release two screws on the seat lock switch.

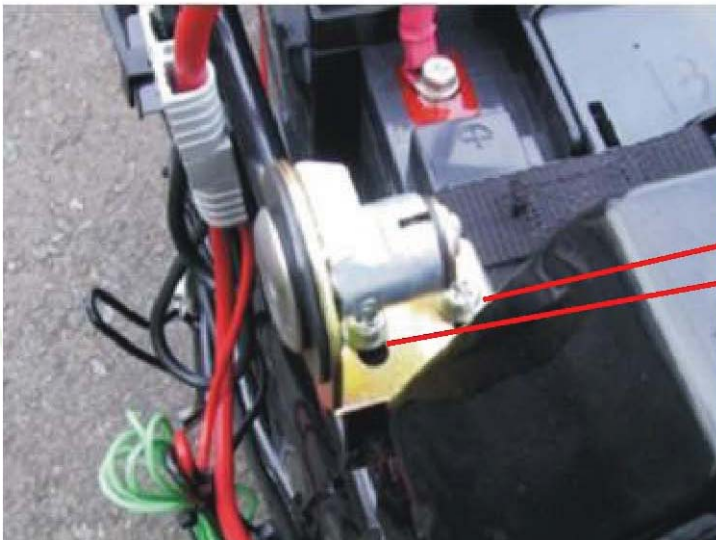

5. Remove the seat lock and seat lock switch.
6. Follow with the reversed steps to restore.

Horn

Tools Required: Open-end wrench, 10mm

Time: Allow 10 minutes for procedure

1. Remove the front cover.
2. Release two connectors on the horn.
3. Release the screw on the horn.

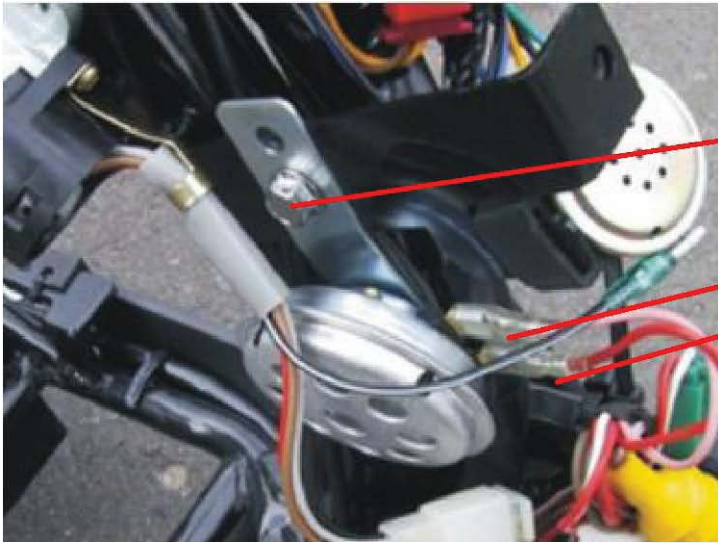

4. Follow with the reversed steps to restore.

Flasher Relay

Time: Allow 10 minutes for procedure

1. Remove the front cover.
2. Release the 2-pin connector on the flasher relay.



3. Follow with the reversed steps to restore.

DC to DC Converter

Tools Required: Phillips screwdriver

Time: Allow 10 minutes for procedure

1. Remove the side covers and footrest board.
2. Release the 4-pin connector for the converter.
3. Release three screws on the converter.

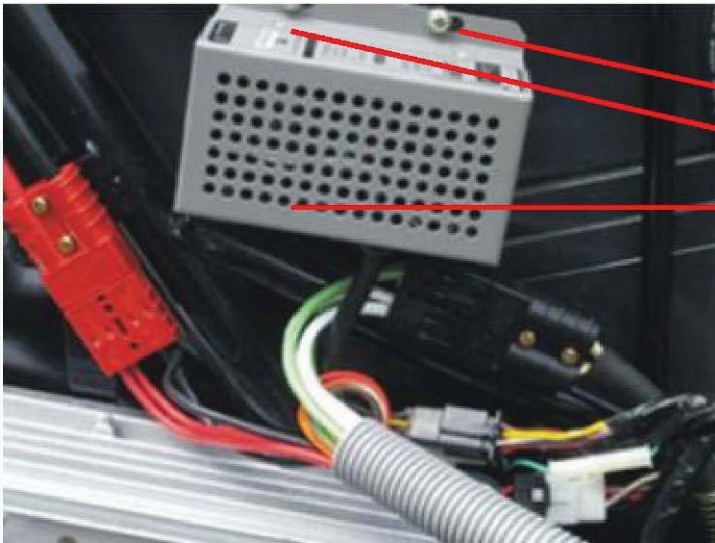

4. Follow with the reversed steps to restore.

Controller

Tools Required: Phillips screwdriver

Time: Allow 10 minutes for procedure

1. Remove the right side cover.
2. Release connectors of controller wire harness.
3. Release the copper nut throttle cable and remove (replace with nail to prevent pillar drawing back).



4. Release four screws on the controller, cut off band.



5. Follow with reversed steps to restore.

Rear Shock Absorber

Tools Required: T-bend socket wrench, 10mm

Time: Allow 10 minutes for procedure

1. Remove the rear body cover.
2. Release two screws on the rear shock absorber.



3. Follow with the reversed steps to restore.

Rear Caliper

Tools Required: Box wrench; Y-bend socket wrench, 12mm

Time: Allow 10 minutes for procedure

1. Release the screw on the rear caliper. Avoid leaking fuel onto the pad.



24

2. Release the screw on the pad.
3. Release two mounting screws on the caliper.
4. Follow with the reversed steps to restore.

Brake Master Cylinder

Tools Required: Box wrench, 12mm; hex-key wrench, 5mm

Time: Allow 10 minutes for procedure

1. Check the fluid in reservoir for refuel or replace the brake fluid.
2. Replace reservoir if leakage occurs, or if gasket fails or wears out.
3. Release the screw on the brake hose.



4. Release two screws on the reservoir.
5. Release two connectors and remove the master cylinder.

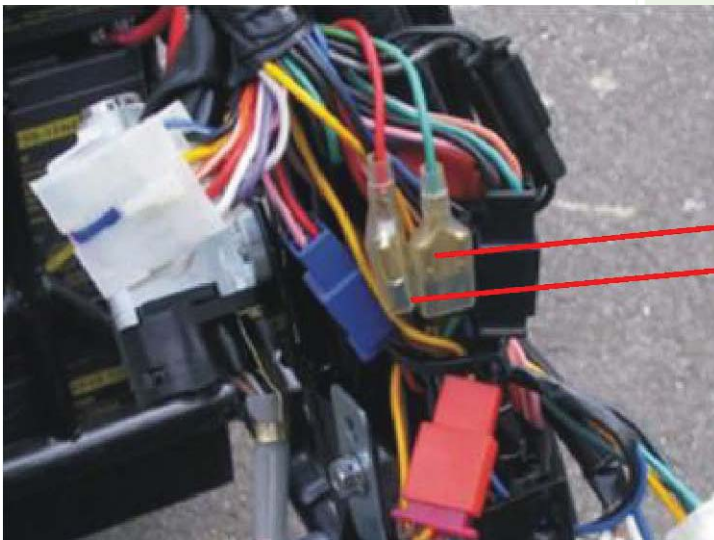

6. Follow with the reversed steps to restore.

Brake Hose

Tools Required: Box wrench; diagonal cutting pliers

Time: Allow 10 minutes for procedure

1. Remove all the covers and fenders.
2. Release the screw on the brake hose of the rear caliper. Avoid leaking fuel onto the pad.
3. Release the screw on the brake hose of master cylinder.



4. Cut off the band on the brake hose and remove.
5. Follow with the reversed steps to restore.

Brake Fluid

Tools Required: Phillips screwdriver

Time: Allow 10 minutes for procedure

1. Release two screws on the cover of the master cylinder.



2. Place tube and fluid vacuum on the rear caliper's screw.
3. Pour brake fluid into the master cylinder.
4. Release the screw on the rear caliper and operate the fluid vacuum.
5. Pull the brake lever several times. Ensure brake is functioning normally and brake hose is free of air.
6. Restore cover of master cylinder.

Brake Pad

Tools Required: Y-bend socket wrench, 12mm

Time: Allow 10 minutes for procedure

1. Release the screw on the rear caliper.
2. Remove the rear caliper.



3. Remove the brake pad from the base of the caliper.
4. Follow with the reversed steps to restore.

Direct Driven Hub-Motor

Tools Required: Phillips screwdriver; open end wrench, 24mm

Time: Allow 10 minutes for procedure

1. Release three screws on the motor cord cover.



2. Cut off the band.
3. Release the black connector of the motor cord.
4. Remove the rear caliper.
5. Release two nuts for the motor shaft.
6. Remove the orientation boards.
7. Remove the motor.
8. Follow with the reversed steps to restore.

Brake Disk

Tools Required: Hex-key wrench, 6mm

Time: Allow 10 minutes for procedure

1. Remove the motor from the frame.
2. Release three screws on the brake disk.

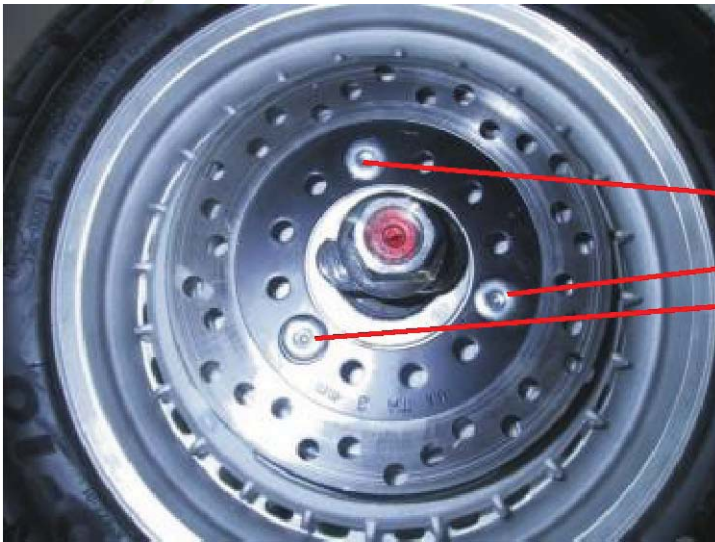

30

3. Remove the brake disk.
4. Follow with the reversed steps to restore.

Rear Fork

Tools Required: Box wrench, 17mm

Time: Allow 10 minutes for procedure

1. Remove the rear caliper, rear motor, and rear shock absorber.
2. Cut off the band on the brake hose and release the screw on the rear fork.



3. Remove the rear fork.
4. Follow with the reversed steps to restore.

Front Shock Absorber

Tools Required: Phillips screwdriver; Y-bend socket wrench, 12mm

Time: Allow 10 minutes for procedure

1. Remove the front fender.
2. Release the screw on the front fork cover and remove.



32

3. Release two screws on the front shock absorber and remove.



4. Follow with the reversed steps to restore.

Head Lamp

Tools Required: Box wrench, 14mm

Time: Allow 10 minutes for procedure

1. Remove the front cover.
2. Release the 6-pin connector.

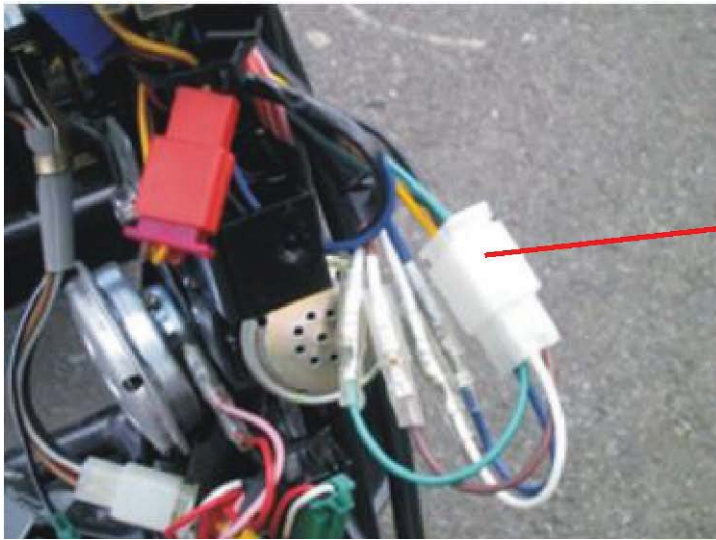

3. Release the screw on the head lamp holder.



4. Follow with the reversed steps to restore.

Front Direction Lamp

Tools Required: Phillips screwdriver

Time: Allow 10 minutes for procedure

1. Remove the front cover.
2. Release the 2-pin connector on the front direction lamp (Green, left; red, right).



34

3. Release the screw on the handle switch and remove the direction lamp.
4. Follow with the reversed steps to restore.

Current Meter and Speedometer

Tools Required: T-bend socket wrench, 8mm

Time: Allow 10 minutes for procedure

1. Remove the front cover.
2. Release the 6-pin connector and the 2-pin connector on the meters.

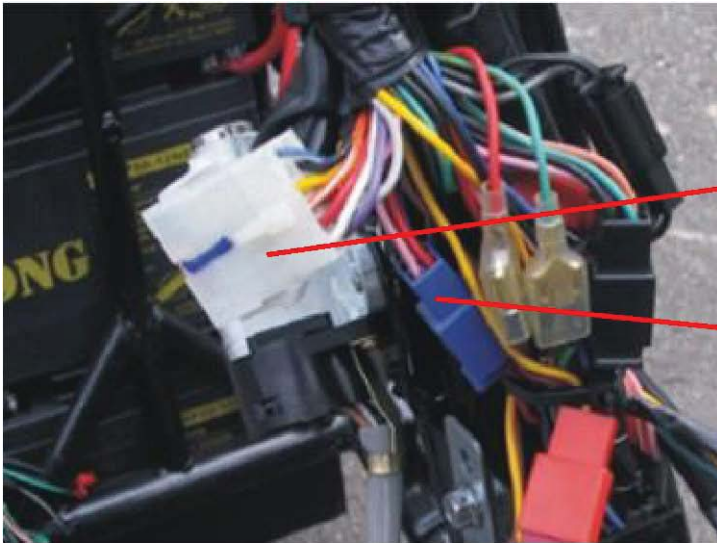

3. Release two screws on the instrument panel.

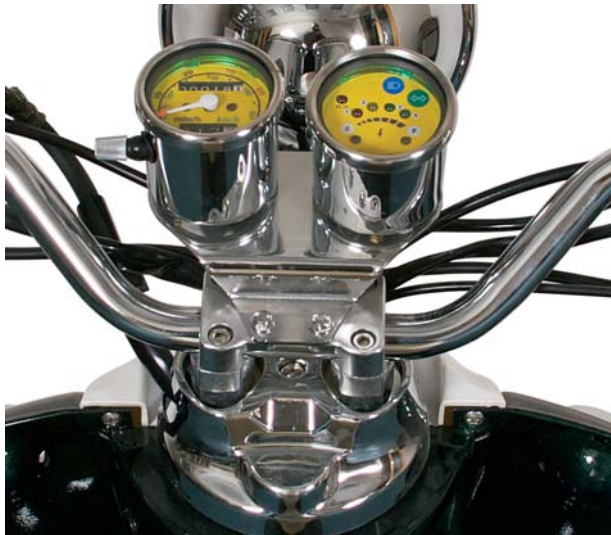

4. Release the nut for the speedometer and remove the instrument panel.
5. Follow with the reversed steps to restore.

Left Handle Switch

Tools Required: Phillips screwdriver

Time: Allow 10 minutes for procedure

1. Remove the front cover.
2. Release all connectors for the left handle switch.

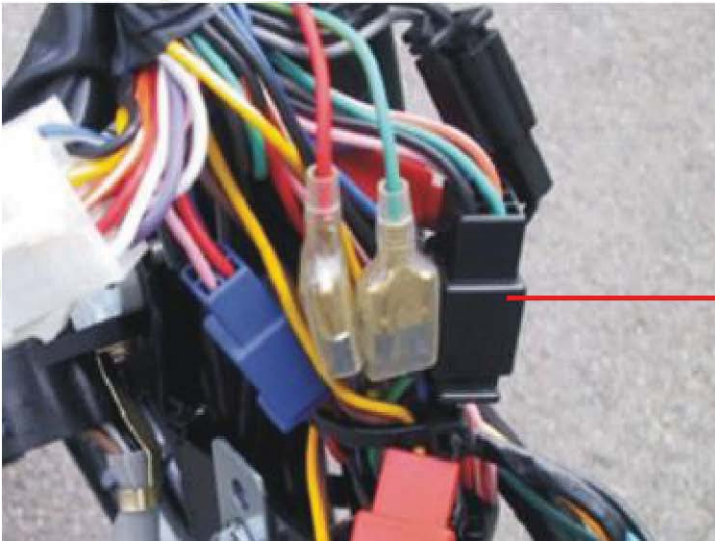

36

3. Release two screws on the left handle switch.



4. Follow with the reversed steps to restore.

Right Handle Switch

Tools Required: Phillips screwdriver

Time: Allow 10 minutes for procedure

1. Remove the front cover.
2. Release all connectors for the right handle switch.

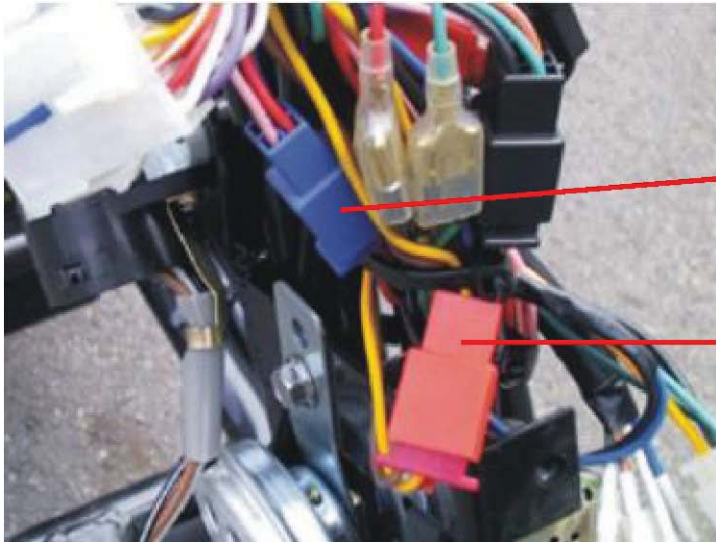

3. Release two screws on the right handle switch.



4. Follow with the reversed steps to restore.

Tail Lamp Assembly

Tools Required: Open-end wrench, 10mm

Time: Allow 10 minutes for procedure

1. Remove the rear fender.
2. Release the three screws on the base of the tail lamp assembly.



38

3. Release all connectors for the tail lamp assembly.

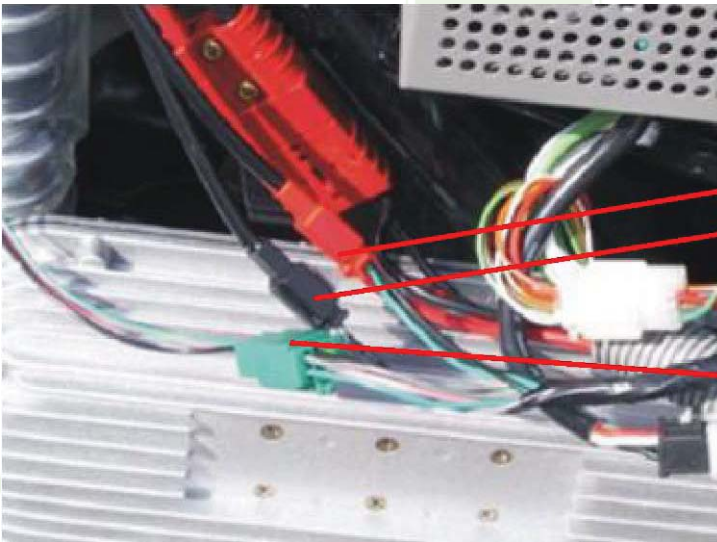

4. Follow with the reversed steps to restore.

Front Brake Cable

Time: Allow 10 minutes for procedure

1. Remove the front cover.
2. Release the adjusting bolt on the brake cable and pull out the brake cable



3. Remove the brake cable from the brake cable head.



4. Follow with the reversed steps to restore.



Throttle Cable

Tools Required: Phillips screwdriver

Time: Allow 10 minutes for procedure

1. Follow page 22 (step 1 to step 3) to pull the throttle pillar out.
2. Follow page 37 (step 1 to step 3) to remove the handle switch.
3. Remove the throttle cable head on the handle grip.



4. Release the screw on the right handle switch.



5. Remove the throttle cable.
6. Follow with the reversed steps to restore.

Handle

Tools Required: hex-key wrench (5mm)

Time: Allow 10 minutes for procedure

1. Remove the instrument panel, handle switches (right and left) and brake master cylinder.
2. Release four screws on the handle Clamp.

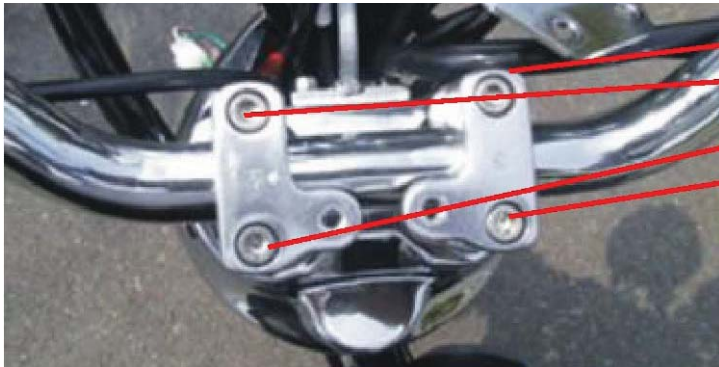

3. Remove the handle.
4. Follow with the reversed steps to restore.

Steering Bracket

Tools Required: Phillips screwdriver, box wrench (14mm)

Time: Allow 10 minutes for procedure

1. Remove handle.
2. Release the screw on the steering bracket cover.



3. Remove the steering bracket cover.
4. Release the screw on the steering bracket.

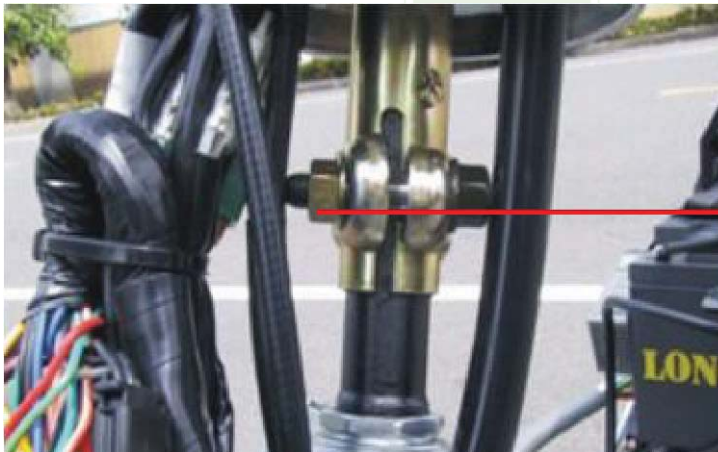

5. Remove the steering bracket.
6. Follow with the reversed steps to restore.

Front Fork and Ball Race

Tools Required: open-end wrench (32mm, 45mm)

Time: Allow 10 minutes for procedure

1. Remove front covers, instrument panel, head lamp, handle and steering bracket.
2. Remove front wheel.
3. Release the nut on the ball race and check the steel balls to see if they are missing.
4. Properly adjust the front fork clearance and follow with the reversed steps to restore.



Part Summary

FIG.01 FRONT WHEEL

Item NO.	Part NO.	Description	Qty.
1	0268-01003501	RIM, FRONT	1
2	0268-01005500	FRONT WHEEL ASSEMBLY	1
3	6277-100105	DRUM BRAKE COMP., FRONT	1
4	0168-01001300	SHAFT, FRONT FORK	1
5	6278-100205	COVER, SHAFT	1
6	0268-0100550A	DUST COVER (LARGE)	1
7	0268-0100550B	DUST COVER (SMALL)	4
8	0268-01006500	COVER, METER GEAR	1
9	0268-01002900	SCREW, SHAFT	1
10	0268-01003700	BEARING	2
11	0268-04000300	OIL SEAL	1
12	0268-01003800	COVER, FRONT RIM	1
13	6270-30010	BRAKE PAD, DRUM BRAKE	2
14	6240-00001	TIRE, TUBELESS	1
15	0241-10601	TIRE VALVE	1
16	6148-100104	COLLAR, F. WHEEL	1

FIG.01

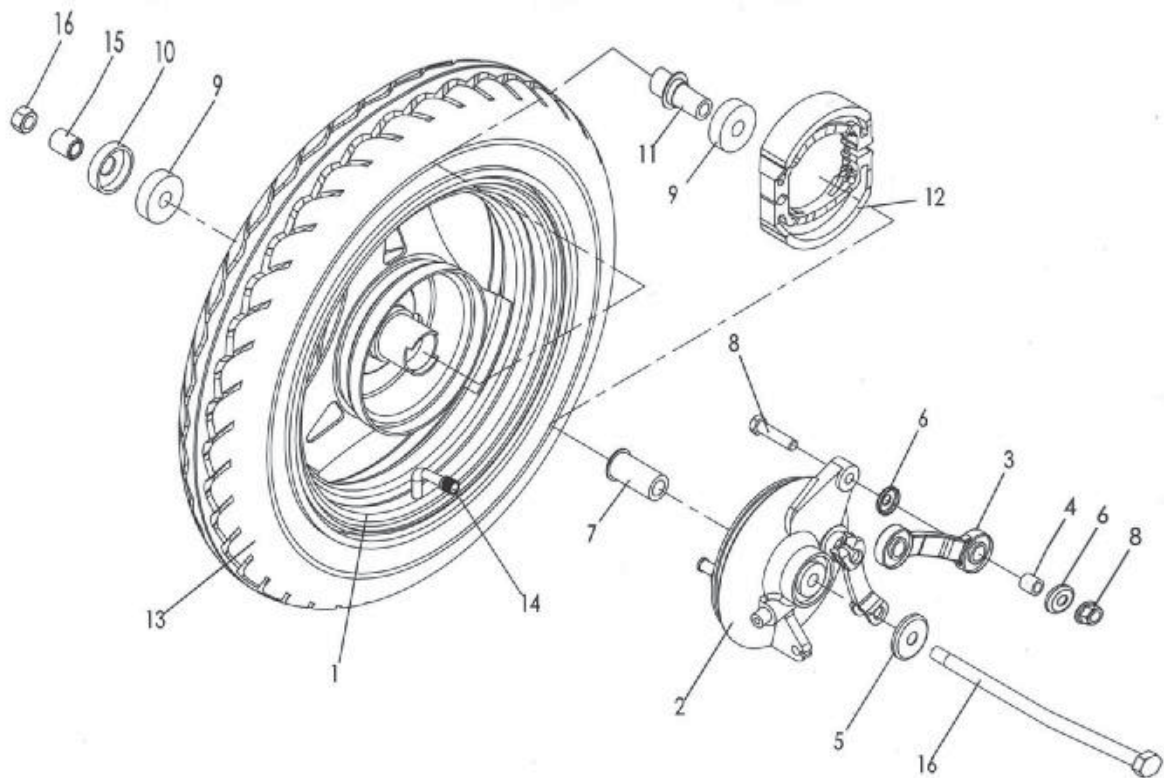

Part Summary (cont'd)

FIG.02 FORK

Item NO.	Part NO.	Description	Qty.
1	0268-01003601	FRONT FORK	1
2	0168-01001300	SWING ARM SET, LEFT & RIGHT	1
3	0268-010046A1	SHOCK ABSORBER, FRONT	2
4	6112-080358	SCREW, HEX./FLANGE	4
5	6141-080758	NUT, HEX./FLANGE	2
6	0268-01003400	RACE, BALL SET	1
7	0268-30201	CHROME COVER, L. CUSHION	2
8	6127-061511	SCREW, PAN/+	2

FIG.02

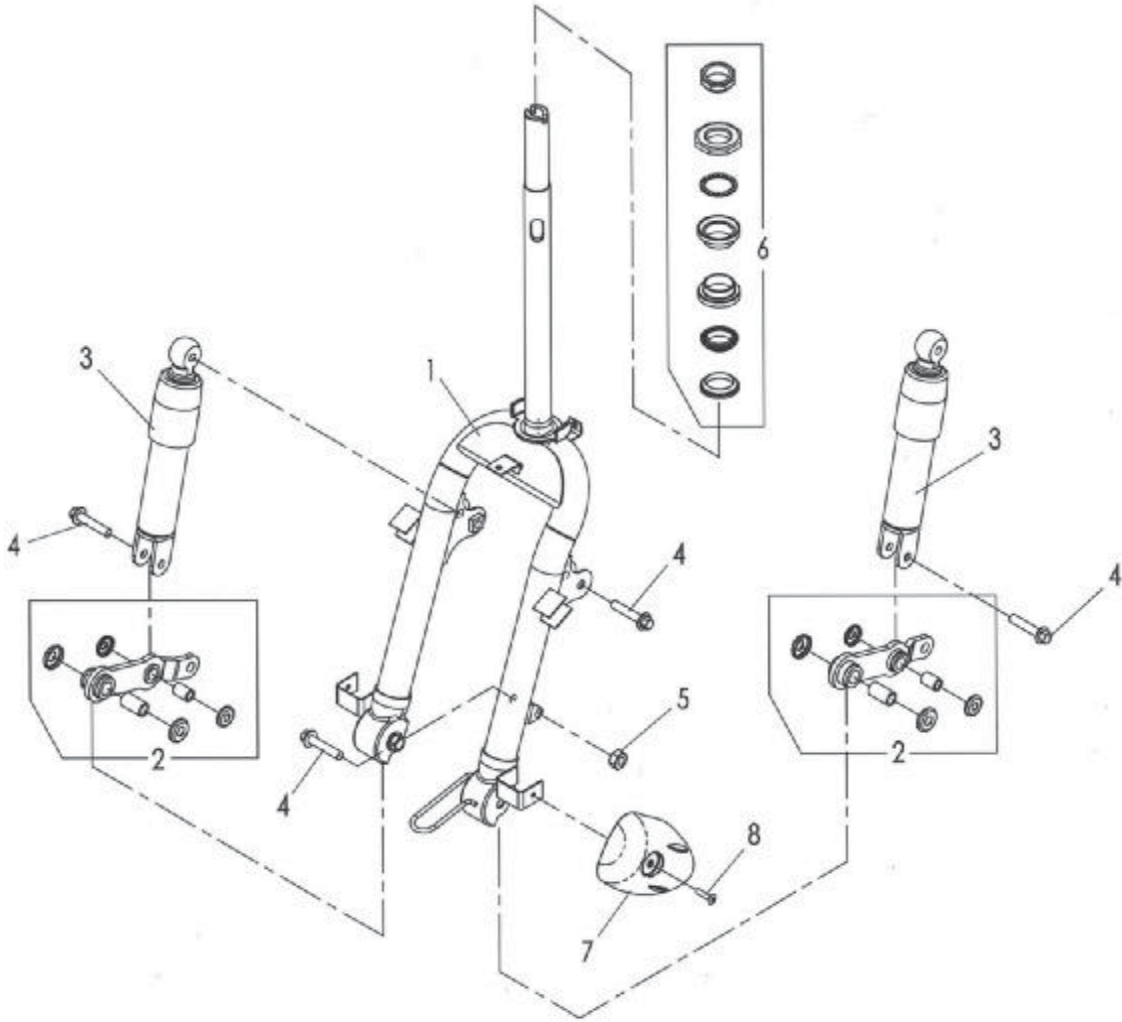

Part Summary (cont'd)

FIG.03 REAR WHEEL

Item NO.	Part NO.	Description	Qty.
1	02A9-05000101	MOTOR ASSY.	1
2	0241-20201	BRAKE DISC, REAR	1
3	6240-00001	TIRE, TUBELESS	1
4	6109-080201	SCREW, BRAKE DISC	3
5	0241-10601	TIRE VALVE	1
6	6248-00001	CONNECTOR, BLACK	1
7	0268-01005901	REAR FORK SET	1
8	6113-103001	BOLT (M10*300)	1
9	6143-100801	NUT, DOME (M10 *8)	1
10	6150-1030305	PLAIN WASHER	4
11	0299-01001501	SHOCK ABSORBER, REAR	2
12	6112-080358	BOLT, HEX. FLANGE	2
13	6111-100407	BOLT, HEX. FLANGE	2
14	0268-30501	CALIPER, REAR	1
15	6112-080168	SCREW, HEX. FLANGE	2
16	0299-010016C3	COVER, MOTOR CORD	1
17	6126-041001	SCREW, PAN	3
18	6141-100908	NUT, HEX./FLANGE	2
19	6151-0815208	SPRING WASHER	2
20	6274-100110	BRACKET, REAR FENDER. (Left)	1
21	6274-110110	BRACKET, REAR FENDER. (Right)	1
22	0299-24000100	REAR FENDER	1

46

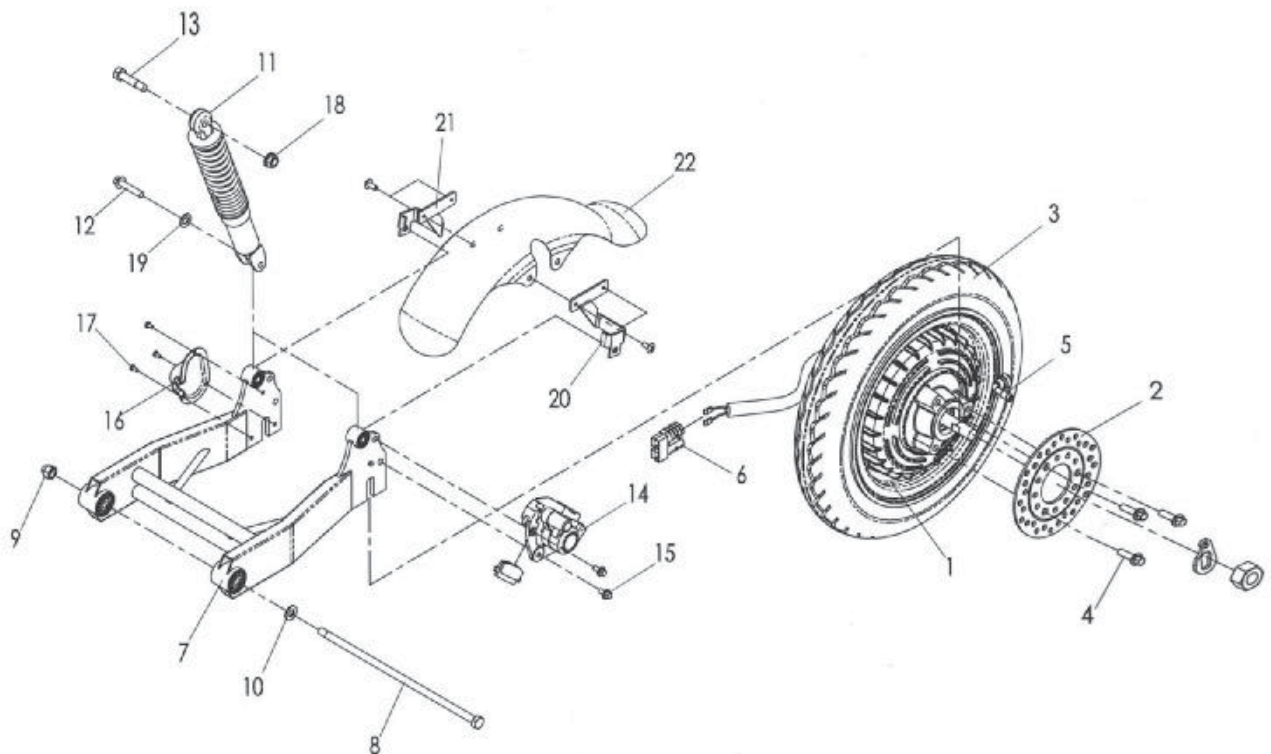

FIG.03

Part Summary (cont'd)

FIG.04 FRAME

Item NO.	Part NO.	Description	Qty.
1	0268-01001100	FRAME	1
2	6266-100104	MAIN STAND	1
3	6111-081255	BOLT (M8*125)	1
4	6142-080855	NUT, FLANGE (M8)	1
5	0268-50301	SPRING, MAIN STAND	2
6	6266-200103	SIDE STAND	1
7	0268-05002200	LOCK SET	1
8	6112-060146	SCREW, HEX. FLANGE (M6*14)	2
9	0268-01004702	TAIL BRACKET	1
10	6100-080201	SCREW, SOCKET (M8*20)	1
11	6144-060601	NUT, DOME (M6)	2

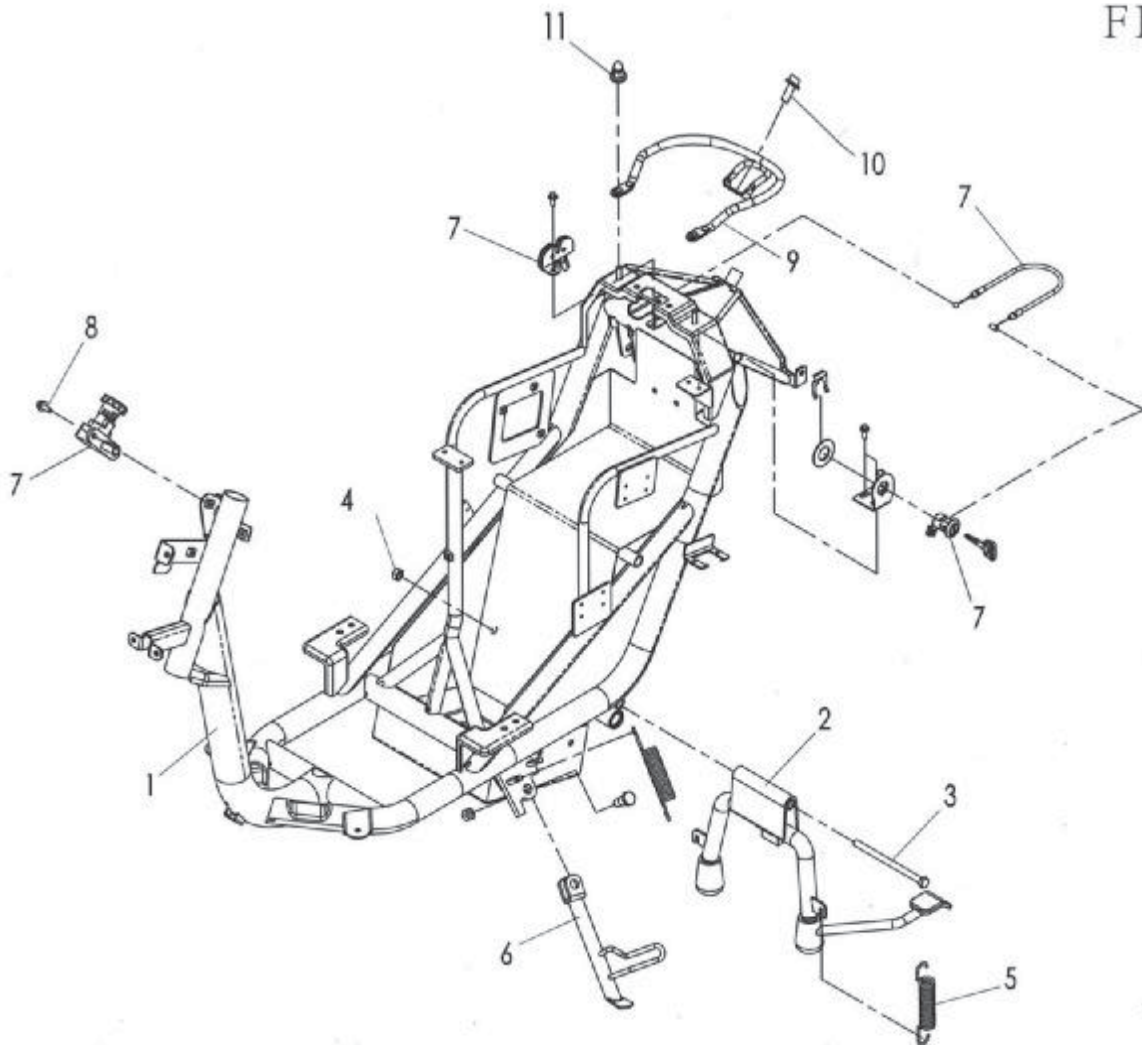

FIG.04

Part Summary (cont'd)

FIG.05 CONTROLLER

Item NO.	Part NO.	Description	Qty.
1	0268-05002802	CONTROLLER (DOT)	1
2	6126-052005	SCREW, PAN HEAD (M5*20)	4
3	6255-00001	HORN	1
4	6112-060126	SCREW, HEX. FLANGE (M6*12)	1
5	0268-05003000	FLASHER RELAY(DOT)	1
6	0268-05002300	DC/DC CONVERTER (DOT)	1
7	0268-05000101	MAIN CONTROL CORD (DOT)	1
8	6256-00200	TIE BAND, Medium	7
9	6256-00280	TIE BAND, Long	3
10	6126-051031	SCREW, PAN HEAD (M5*10)	2
11	0299-01001700	THROTTLE CABLE	1

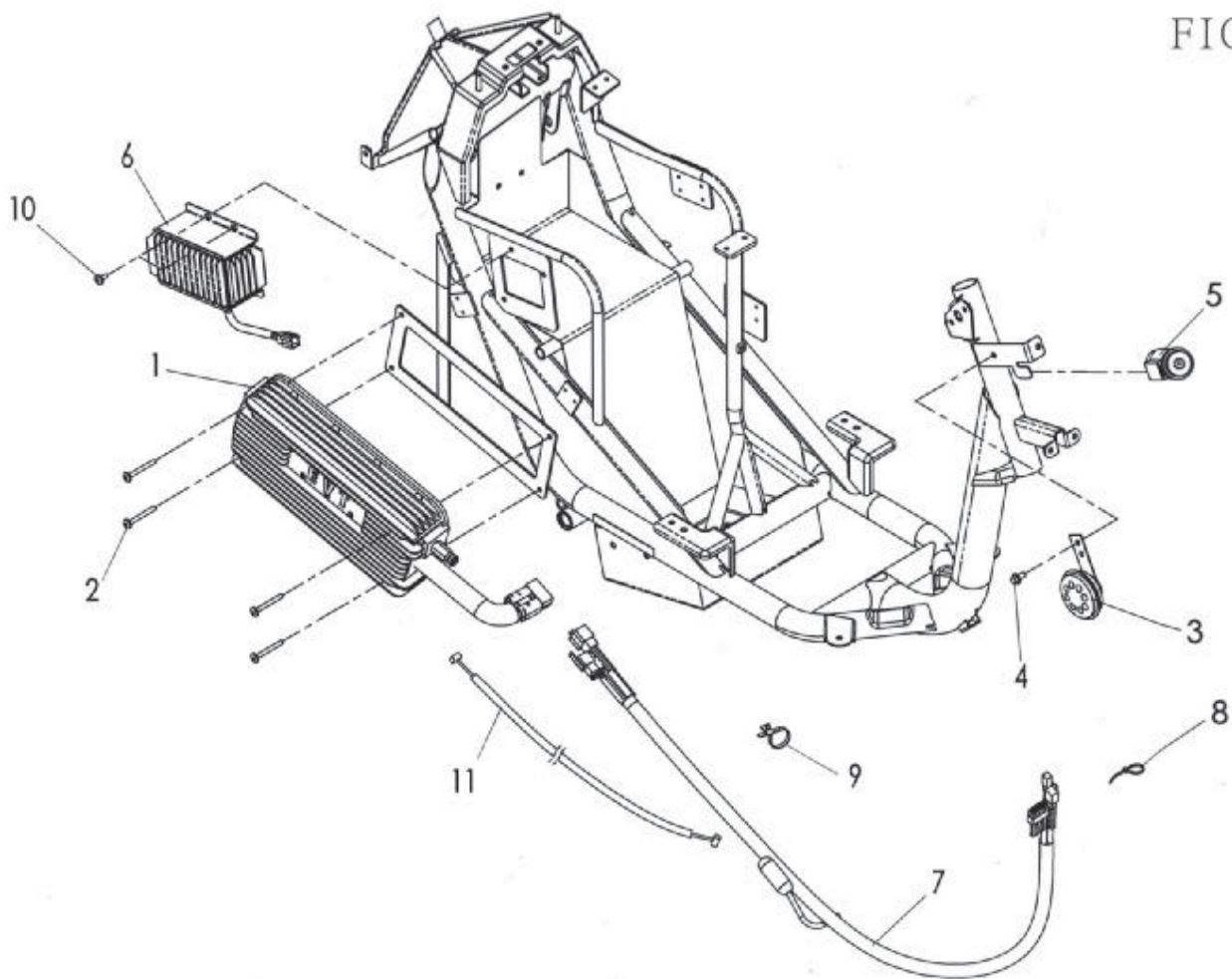

FIG.05

Part Summary (cont'd)

FIG.06 HANDLE BAR

Item NO.	Part NO.	Description	Qty.
1	0268-42301	STEERING BRACKET	1
2	6111-100407	SCREW, HEX./FLANGE	1
3	6141-100908	NUT, HEX./FLANGE	1
4	0268-42401	CHROME COVER, STRG. BRACKET	1
5	0268-01001600	LOWER HANDLE CLAMP	2
6	0268-40101	HANDLE	1
7	0268-01001700	UPPER HANDLE CLAMP, LEFT	1
8	0268-01001800	UPPER HANDLE CLAMP, RIGHT	1
9	0268-05001900	HANDLE SWITCH, LEFT	1
10	0268-05002001	HANDLE SWITCH, RIGHT (DOT)	1
11	0268-40900	MASTER CYLINDER, LEFT	1
12	6283-200141	BRAKE HOSE, REAR	1
13	0241-41901	SCREW, BRAKE HOSE	2
14	0241-41902	WASHER, BRAKE HOSE	4
15	0268-05003201	FRONT WINKER, RIGHT (DOT)	1
16	0268-05003200	FRONT WINKER, LEFT (DOT)	1
17	0241-41402	BRACKET, LEFT WINKER	1
18	0241-41404	BRACKET, RIGHT WINKER	1
19	6126-051031	SCREW, PAN/+	2
20	6170-100110	HANDLE GRIP, LEFT	1
21	6170-100210	HANDLE GRIP, RIGHT	1
22	0268-01005300	REAR VIEW MIRROR SET	1
23	0268-01005600	BRAKE LEVER, LEFT	1
24	0268-01004801	BRAKE LEVER, RIGHT	1

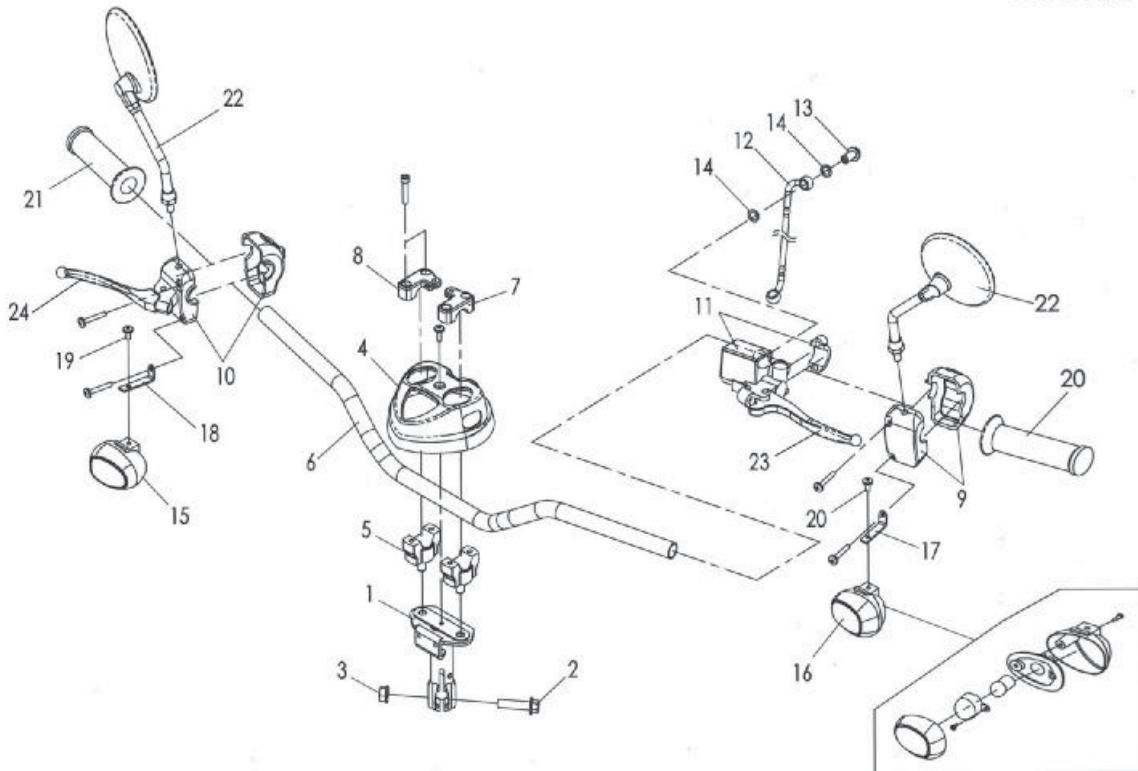

FIG.06

Part Summary (cont'd)

FIG.07 METER/HEAD LIGHT

Item NO.	Part NO.	Description	Qty.
1	0268-42601	BRACKET, METER ASSY.	1
2	0268-425011	BRACKET, HEADLIGHT	1
3	6141-060608	NUT, HEX./FLANGE	2
4	0268-05003100	HEADLIGHT COMP. (DOT)	1
5	6113-080406	SCREW, HEX./FLANGE	1
6	6141-080756	NUT, HEX./FLANGE	1
7	0268-050025A1	CURRENT METER	1
8	0268-05002601	SPEEDOMETER (DOT)	1
9	0268-01004100	COPPER COVER	4
10	0268-04000400	RUBBER COVER	4
11	0268-014000211	NUT, HEX./FLANGE	4
12	6112-060146	SCREW, HEX./FLANGE	2
13	0268-41704	CABLE, SPEEDOMETER	1

FIG.07

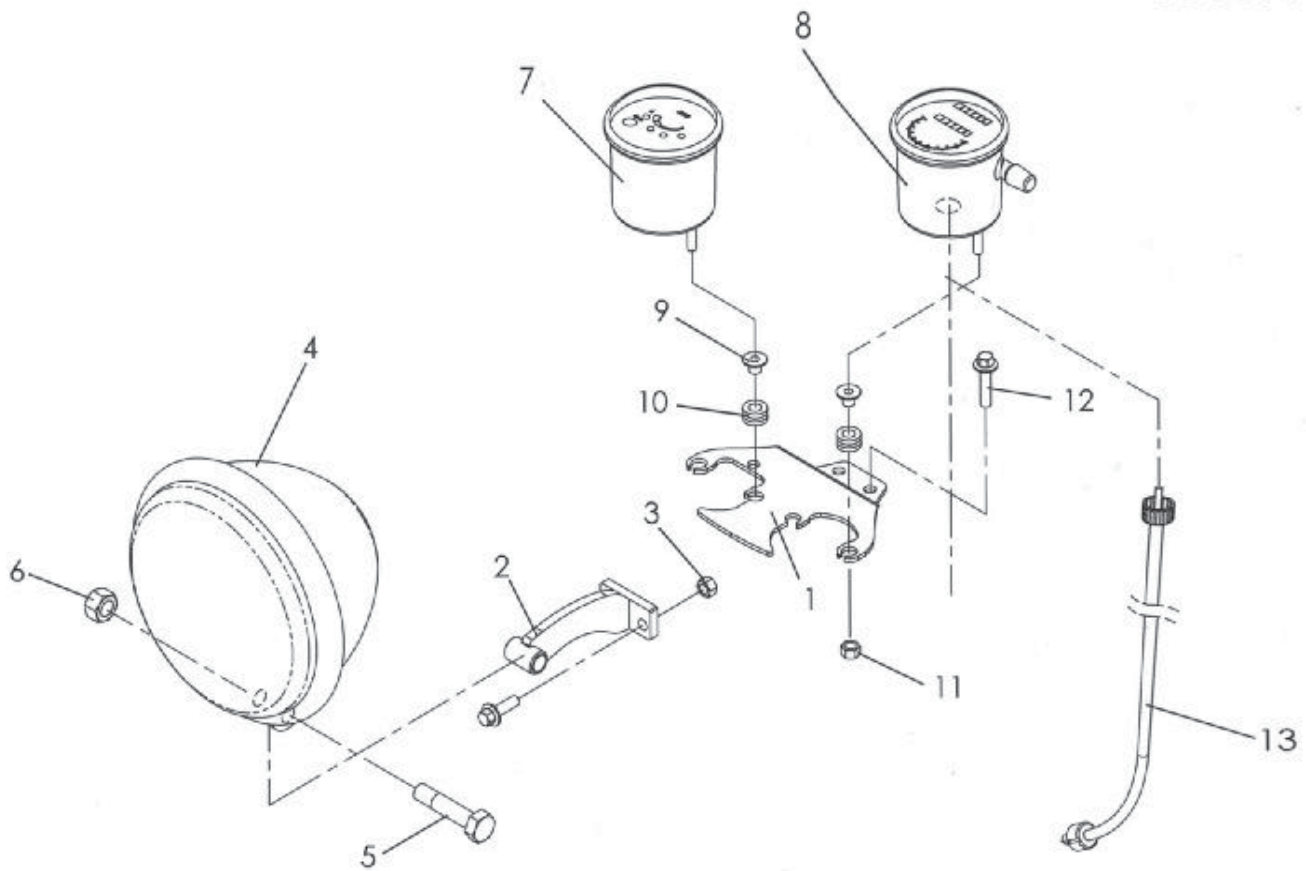

Part Summary (cont'd)

FIG.08 TAIL LAMP

Item NO.	Part NO.	Description	Qty.
1	6263-210102	TAIL LAMP COVER	1
2	6263-21101	TAIL LAMP	1
3	6276-200161	PLATE, LICENCE PLATE	1
4	0268-05003300	DIRECTIONAL LAMP, REAR (L) (DOT)	1
5	0268-05003301	DIRECTIONAL LAMP, REAR (R) (DOT)	1
6	0268-71104	MOUNTING PLATE, TAIL LAMP	1
7	0268-71701	REAR FENDER	1
8	6246-10002	REFLECTOR	1
9	6112-060146	SCREW, HEX./FLANGE	2
10	6141-0804758	NUT, HEX./FLANGE	2
11	6113-0603561	SCREW, HEX./FLANGE	3
12	6141-060606	NUT, HEX./FLANGE	3
13	6141-080758	NUT, HEX./FLANGE	2
14	6144-060606	NUT, HEX./FLANGE	2

FIG.08

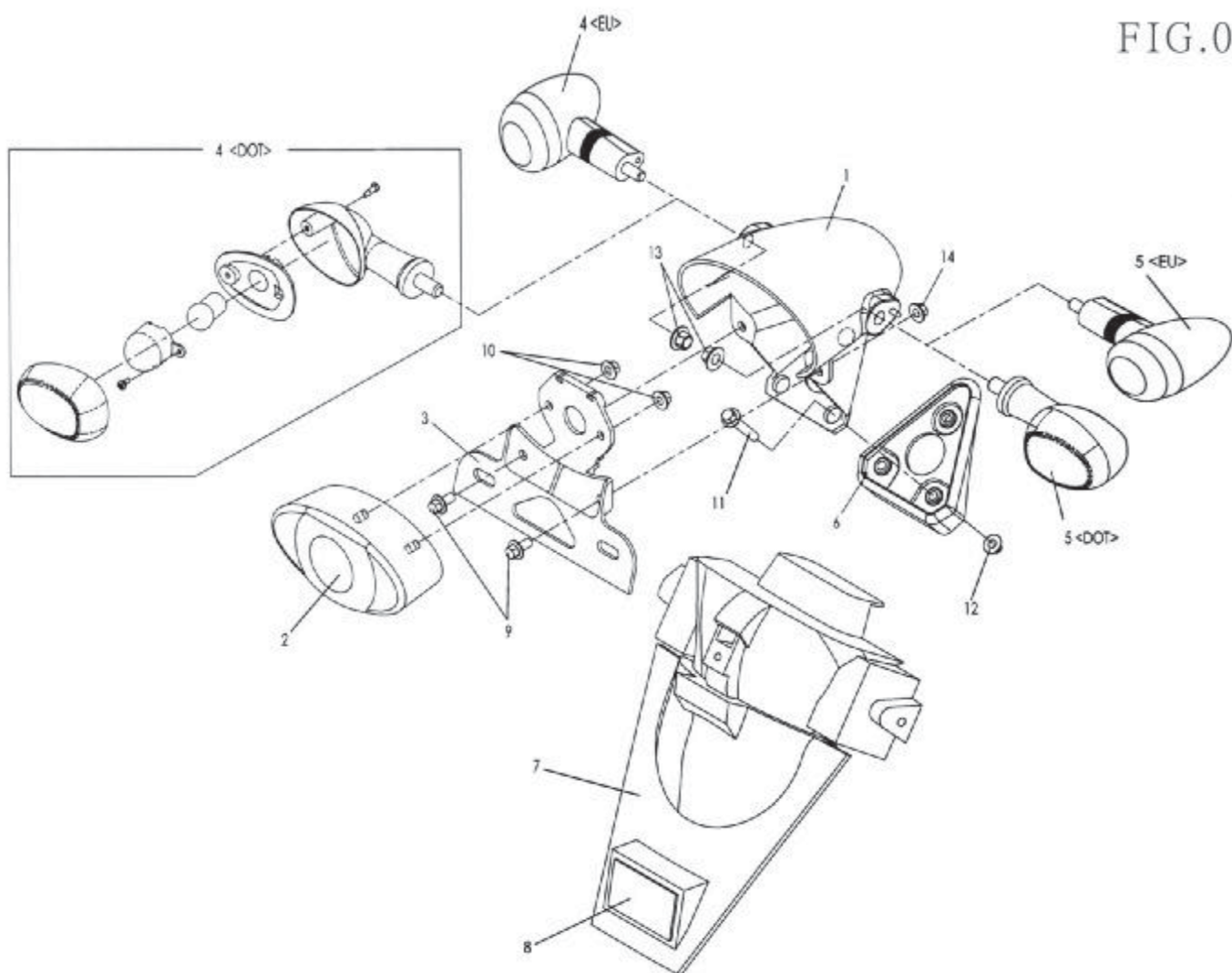

Part Summary (cont'd)

FIG.09 SEAT

Item NO.	Part NO.	Description	Qty.
1	0268-70101	SEATBOX RIM	1
2	0268-01004900	SEAT HINGE	1
3	6112-060126	SCREW, HEX./FLANGE	2
4	0268-24000200	SEAT	1
5	0268-01004910	PIN, SEAT	1
6	0268-72301	BRACKET, SEAT	1
7	6141-060608	NUT, HEX./FLANGE	2

FIG.09

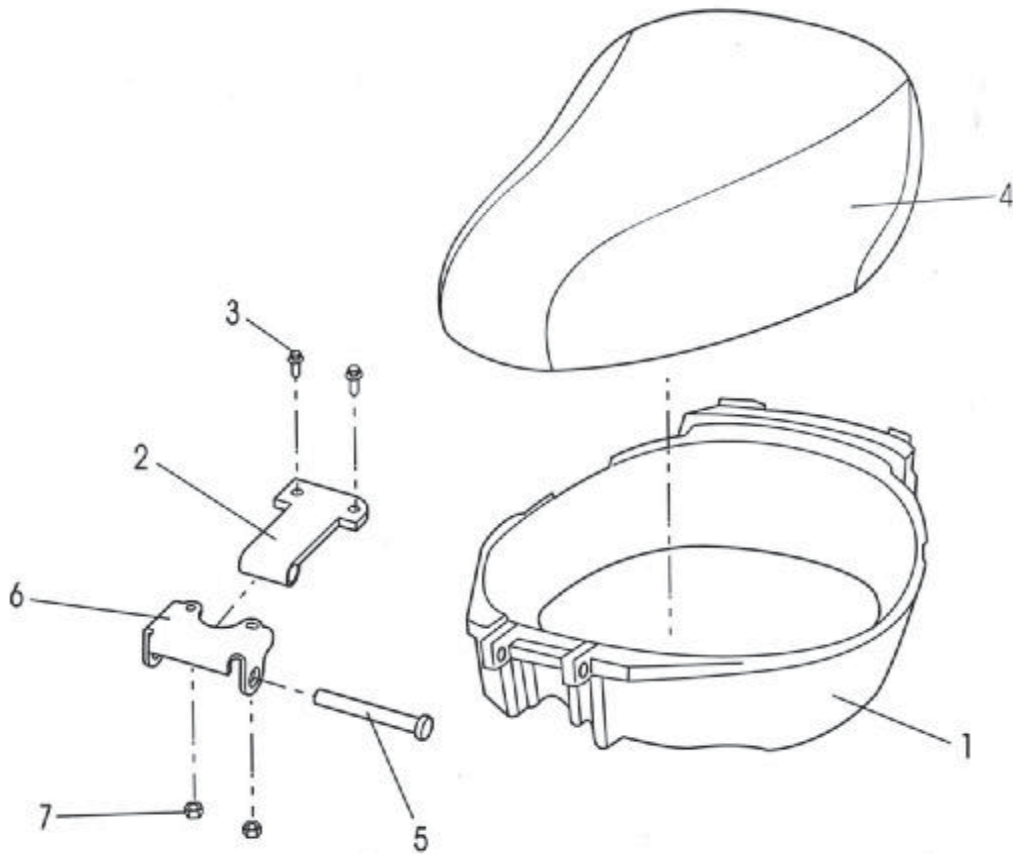

Part Summary (cont'd)

FIG.10 FRONT COVER

Item NO.	Part NO.	Description	Qty.
1	0268-13003001	FAIRING (LIGHT BLUE)	1
	0268-13003002	FAIRING (LIGHT ORANGE)	1
	0268-13003003	FAIRING (DARK GREEN)	1
	0268-13003004	FAIRING (PURPLE RED)	1
2	0268-70891	R. PLUG, FAIRING	1
3	0268-70892	L. PLUG CAP, FAIRING	1
4	0268-70893	HANGER, SIDE	2
5	6127-061511	SCREW, PAN/+	1
6	6269-210161	FRONT TRIM CAP, LEFT	1
7	6269-210261	FRONT TRIM CAP, RIGHT	1
8	6132-501511	SCREW, TAPPING/+	8
9	6112-060126	SCREW, HEX. FLANGE	1
10	0268-70701	FRONT COVER	1
11	0268-70702	EMBLEM CAP, EVT	1
12	0268-70703	HORN COVER	1
13	0268-71601	F. FENDER, FRONT (LIGHT BLUE)	1
	0268-71608	F. FENDER, FRONT (LIGHT ORANGE)	1
	0268-71605	F. FENDER, FRONT (DARK GREEN)	1
	0268-71604	F. FENDER, FRONT (PURPLE RED)	1
14	0268-71611	F. FENDER, REAR (LIGHT BLUE)	1
	0268-71618	F. FENDER, REAR (LIGHT ORANGE)	1
	0268-71615	F. FENDER, REAR (DARK GREEN)	1
	0268-71614	F. FENDER, REAR (PURPLE RED)	1
15	0268-24000101	REFLECTOR (AMBER)	2
16	6112-060146	SCREW, HEX./FLANGE	1

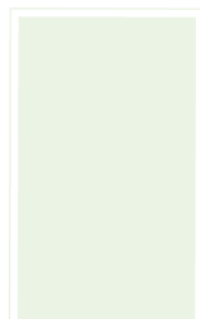
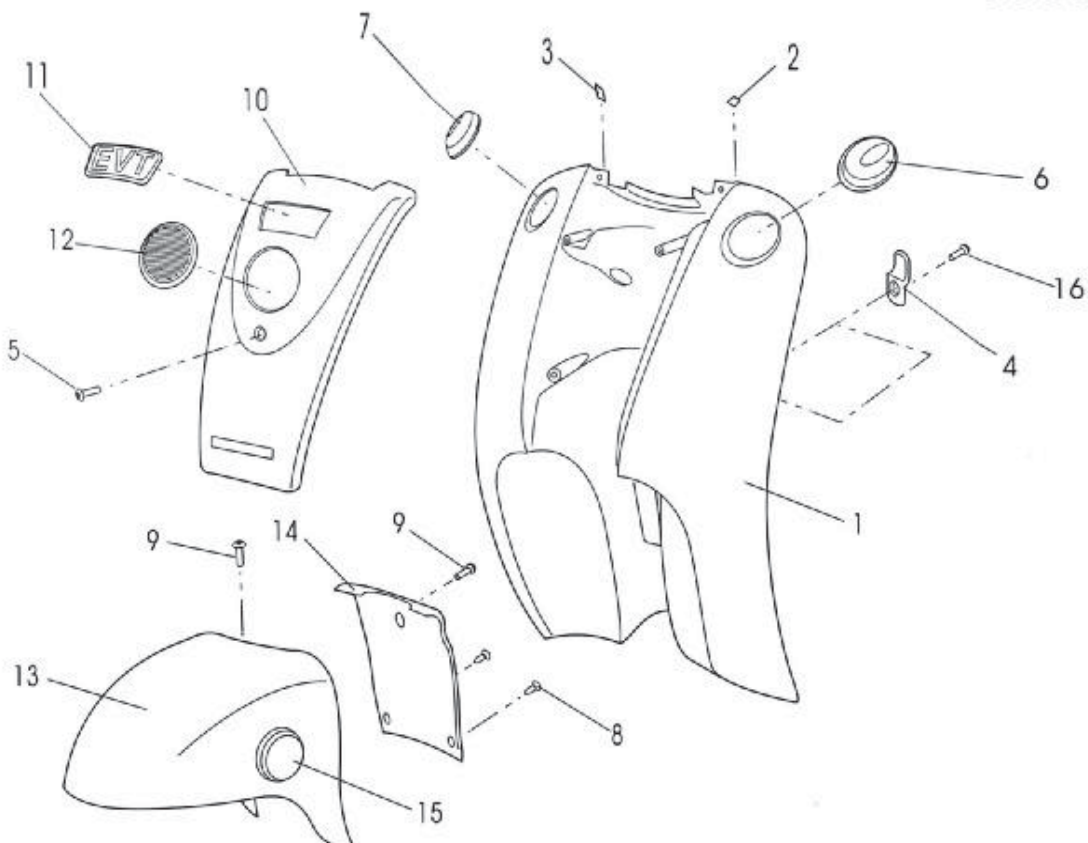

FIG.10



Part Summary (cont'd)

FIG.11 SIDE COVER

Item NO.	Part NO.	Description	Qty.
1	0268-70501	LEFT COVER (LIGHT BLUE)	1
	0268-70508	LEFT COVER (LIGHT ORANGE)	1
	0268-70505	LEFT COVER (DARK GREEN)	1
	0268-70504	LEFT COVER (PURPLE RED)	1
2	0268-70601	RIGHT COVER (LIGHT BLUE)	1
	0268-70608	RIGHT COVER (LIGHT ORANGE)	1
	0268-70605	RIGHT COVER (DARK GREEN)	1
	0268-70604	RIGHT COVER (PURPLE RED)	1
3	6269-200361	OUTER TRIM CAP, L. COVER	1
4	6269-200461	OUTER TRIM CAP, R. COVER	1
5	6132-501511	SCREW, TAPPING/+	13
6	0268-71402	REAR BODY COVER, WHITE	1
7	6258-101001	STICKER, SIDE COVER	1
	6258-101002	STICKER, SIDE COVER	1
8	0268-72401	TRIM CAP, REAR FENDER	1

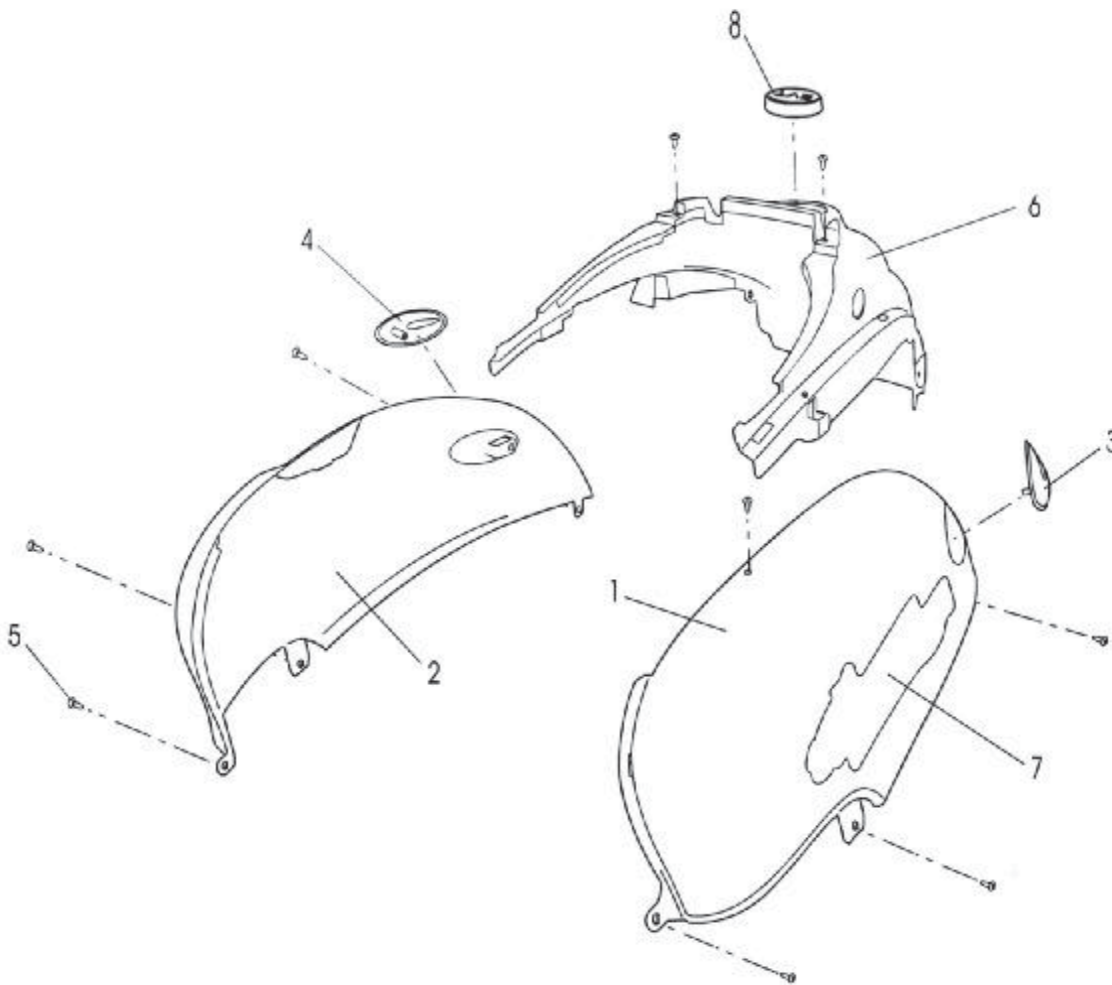

FIG.11

Part Summary (cont'd)

FIG.12 FOOTREST BOARD

Item NO.	Part NO.	Description	Qty.
1	0268-71303	FOOTREST BOARD, LIGHT BROWN	1
2	6112-060126	SCREW, HEX./FLANGE	4
3	0268-71401	FRONT BODY COVER, WHITE	1
	0268-13001309	FRONT BODY COVER, SILVER	1
4	0268-70102	COVER, LOWER	1
5	6127-061511	SCREW, HEX./FLANGE	2
6	6113-0603561	SCREW, HEX./FLANGE	1
7	6150-0613105	WASHER	1
8	0268-24000101	REFLECTOR(RED) (DOT)	2
9	6282-100161	FLOOR MAT	1

FIG.12

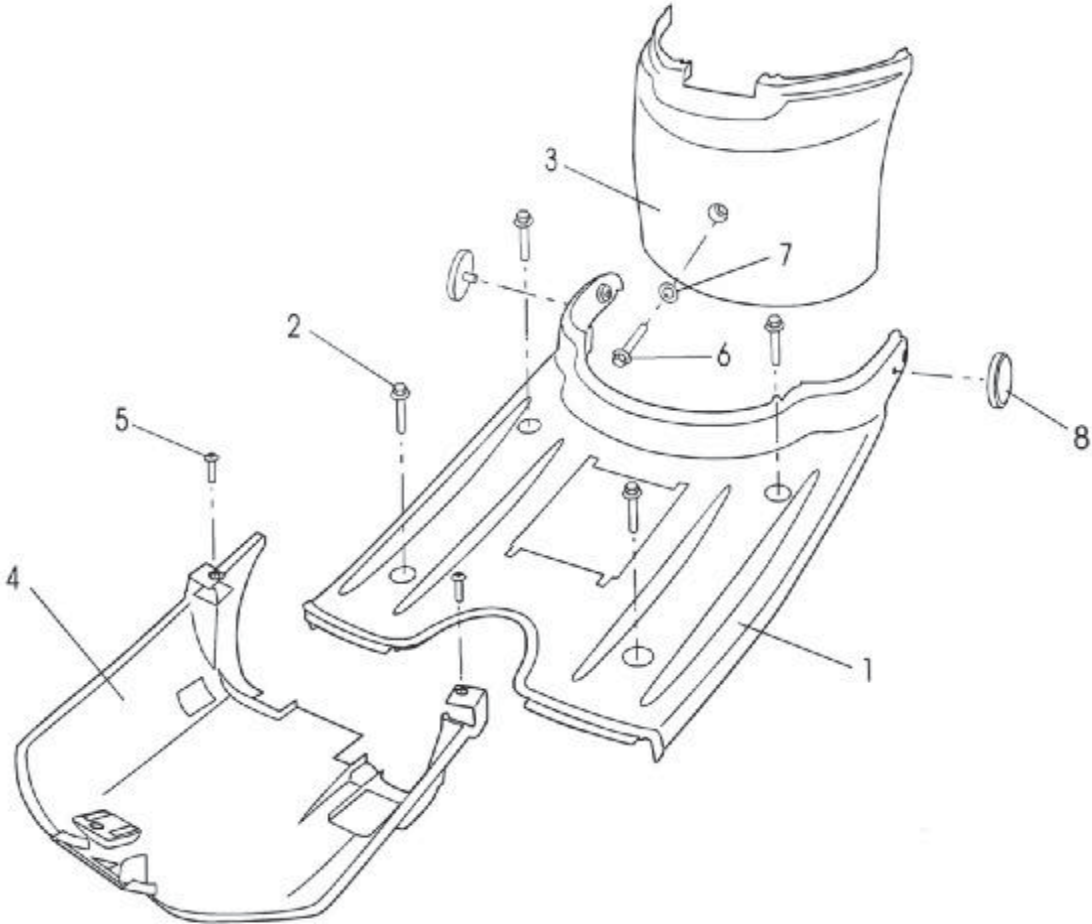

Part Summary (cont'd)

FIG.13 BATTERY

Item NO.	Part NO.	Description	Qty.
1	181-460-10	BATTERY, LEV 12500	4
2	6261-040621	BATTERY CORD SET, LONG	1
	6261-050621	BATTERY CORD SET, SHORT	3
3	0299-05000400	CONNECTION CABLE, BATTERY	1
4	6243-100119	CHARGER	1

FIG.14

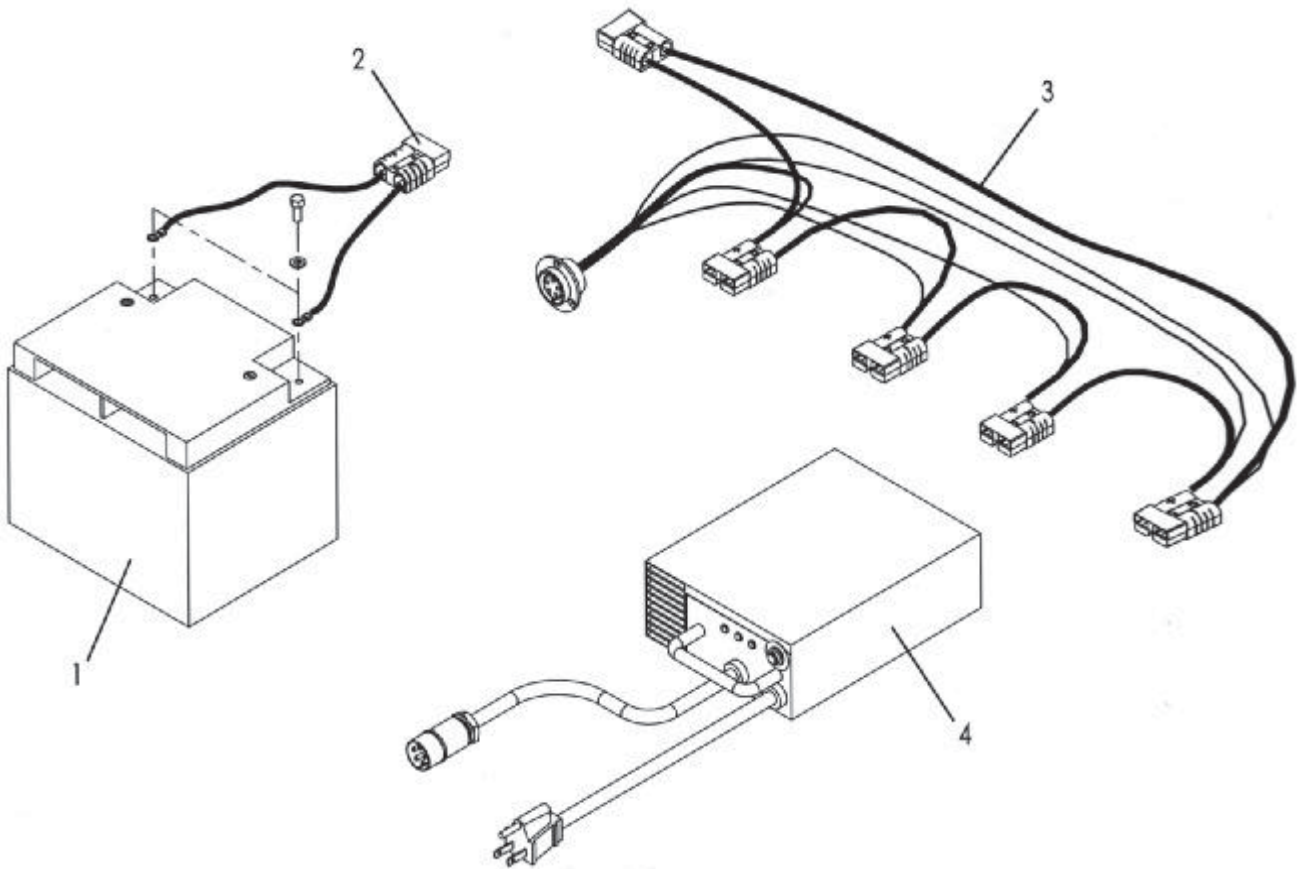

Accessories

Item NO.	Part NO.	Description
1	0268-24000301	STORAGE CASE, LIGHT BLUE
2	0268-24000302	STORAGE CASE, LIGHT ORANGE
3	0268-24000303	STORAGE CASE, DARK GREEN
4	0268-24000304	STORAGE CASE, PURPLE RED
5	0268-24000309	STORAGE CASE, SILVER
6	0268-01004702	EVT-168 CARGO CASE BRACKET
7	0268-13000408	FRONT FENDER, CHROME
8	0241-80901	FRONT BASKET
9	0241-305211	BRAKE PAD, BLUE (UNCUT)
10	0268-41002	BRAKE CABLE, FRONT (1206MM)
11	0242-41001	BRAKE CABLE, REAR
12	745-956-20-006	EV-500 SOLAR CHARGER
13	875-738-20-001	WIRE KIT W/ CONNECTOR FOR EV-500
14	PB-360P-48	LITHIUM BATTERY CHARGER
15	0241-80821	WINDSHIELD
16	0241-808022	WINDSHIELD - ASSEMBLY KIT
17	02A9-05000400	MOTOR BRUSH 8PC SET (BEFORE 2006)
18	02A9-05000500	MOTOR BRUSH 16PC SET (2006-2008)
19	6257-101500	REFURBISHED MOTOR (BRUSH - MODELS THROUGH 2008)