



-pocket mod™

iMod™



*The iPod® product name is used for identification purposes only. iPod® is a registered trademark of Apple Inc.

OWNER'S MANUAL

Read and understand this entire manual before riding!

Item Number:

iMod™

15130699

CONTENTS

Safety Warnings	1	Troubleshooting Guide.....	8-9
Before You Begin.....	2	iMod Parts	10-11
Assembly and Set-Up.....	3-5	Safety Reminders	13
Repair and Maintenance.....	6-7	Warranty	13

SAFETY WARNINGS

⚠ WARNING: Riding the iMod can be a hazardous activity. Certain conditions may cause the equipment to fail without fault of the manufacturer. Like other electric vehicles, the iMod can and is intended to move, and it is therefore possible to lose control, fall off and/or get into dangerous situations that no amount of care, instruction or expertise can eliminate. If such things occur you can be seriously injured or die, even when using safety equipment and other precautions. **RIDE AT YOUR OWN RISK AND USE COMMON SENSE.**

This manual contains many warnings and cautions concerning the consequences of failing to maintain, inspect or properly use your iMod. Because any incident can result in serious injury or even death, we do not repeat the warning of potential serious injury or death each time such a possibility is mentioned.

APPROPRIATE RIDER USE AND PARENTAL SUPERVISION

This manual contains important safety information. It is your responsibility to review this information and make sure that all riders understand all warnings, cautions, instructions and safety topics and assure that young riders are able to safely and responsibly use this product. Razor recommends that you periodically review and reinforce the information in this manual with younger riders, and that you inspect and maintain your children's vehicle to insure their safety.

The recommended rider age of 12 and older for iMod is only an estimate, and can be affected by the rider's size, weight or skills. Any rider unable to fit comfortably on the iMod should not attempt to ride it. **A parent's decision to allow his or her child to ride this product should be based on the child's maturity, skill and ability to follow rules.**

Keep this product away from small children and remember that this product is intended for use only by persons who are, at a minimum, completely comfortable and competent while operating the vehicle.

DO NOT EXCEED THE WEIGHT LIMIT OF 170 pounds (77kg). Rider weight does not necessarily mean a person's size is appropriate to fit or maintain control of the iMod.

Do not touch the motor on your iMod when in use as it can become very hot.

Refer to the section on safety for additional warnings.

ACCEPTABLE RIDING PRACTICES AND CONDITIONS

Always check and obey any local laws or regulations which may affect the locations where the iMod may be used on public property. The iMod is meant to be used only in controlled environments free of potential traffic hazards and not on public streets or sidewalks. Do not ride your iMod in any areas where pedestrian or vehicle traffic is present.

Ride defensively. Watch out for potential obstacles that could catch your wheel or force you to swerve suddenly or lose control. Be careful to avoid pedestrians, skaters, skateboards, scooters, bikes, children or animals who may enter your path, and respect the rights and property of others.

Do not attempt or do stunts or tricks on your iMod. The iMod is not made to withstand abuse from misuse such as jumping, curb grinding or any other type of stunts.

Maintain a hold on the handlebars at all times.

Never carry passengers or allow more than one person at a time to ride the iMod.

Keep your fingers and other body parts away from the drive chain, steering system, wheels and all other moving components.

Never use headphones, earbuds or a cell phone when riding.

Not suited for video iPod® use.

Give full attention to riding. Stop riding and turn of the iMod power switch to "off" before adjusting volume or changing channels.

Never attempt to access iPod® compartment while riding.

Never hitch a ride with another vehicle.

Do not ride the iMod in wet weather and never immerse the iMod in water, as the electrical and drive components could be damaged by water or create other possibly unsafe conditions.

The iMod is intended for use on solid, flat, clean and dry surfaces such as pavement or level ground without loose debris such as rocks or gravel. Never use near steps or swimming pools. Wet, slick or uneven and rough surfaces may impair traction and contribute to possible accidents. Do not ride the iMod in mud, ice, puddles or water. Avoid excessive speeds that can be associated with downhill rides. Never risk damaging surfaces such as carpet or flooring by use of a iMod indoors.

Do not ride at night or when visibility is impaired.

PROPER RIDING ATTIRE

Always wear proper protective equipment such as an approved safety helmet. Elbow pads and kneepads are recommended. A helmet may be legally required by local law or regulation in your area. Always wear shoes, never drive barefooted or in sandals, and keep shoelaces tied and out of the way of the wheels, motor and drive system.

USING THE CHARGER

The charger supplied with the iMod should be regularly examined for damage to the cord, plug, enclosure and other parts, and in the event of such damage, the iMod must not be charged until the charger has been repaired or replaced.

Use only with the recommended charger.

Use caution when charging. Do not exceed charging time.

The charger is not a toy. Charger should be operated by an adult.

Do not operate charger near flammable materials.

Unplug charger and disconnect from the battery operated product when not in use.

Always disconnect from the charger prior to wiping down and cleaning your scooter with liquid.

FAILURE TO USE COMMON SENSE AND HEED THE ABOVE WARNINGS INCREASES RISK OF SERIOUS INJURY. USE WITH APPROPRIATE CAUTION AND SERIOUS ATTENTION TO SAFE OPERATION.

BEFORE YOU BEGIN

Remove contents from box. Remove the foam separators that protect the components from damage during shipping. Inspect the contents of the box for scratches in the paint, dents or kinked cables that may have occurred during shipping. Because the iMod was 95 percent assembled and packed at the factory, there should not be any problems, even if the box has a few scars or dents.

Estimated Assembly and Set-Up Time

Razor recommends assembly by an adult with experience in bicycle mechanics. Allow up to 15 minutes for assembly, not including initial charge time. Allow up to 18 hours for initial charge (see page 3 for charging information).

WARNING:
DO NOT USE NON-RAZOR PRODUCTS WITH YOUR RAZOR iMOD.

The iMod has been built to certain Razor design specifications. The original equipment supplied at the time of sale was selected on the basis of its compatibility with the frame, fork and all other parts. Certain aftermarket products may or may not be compatible.

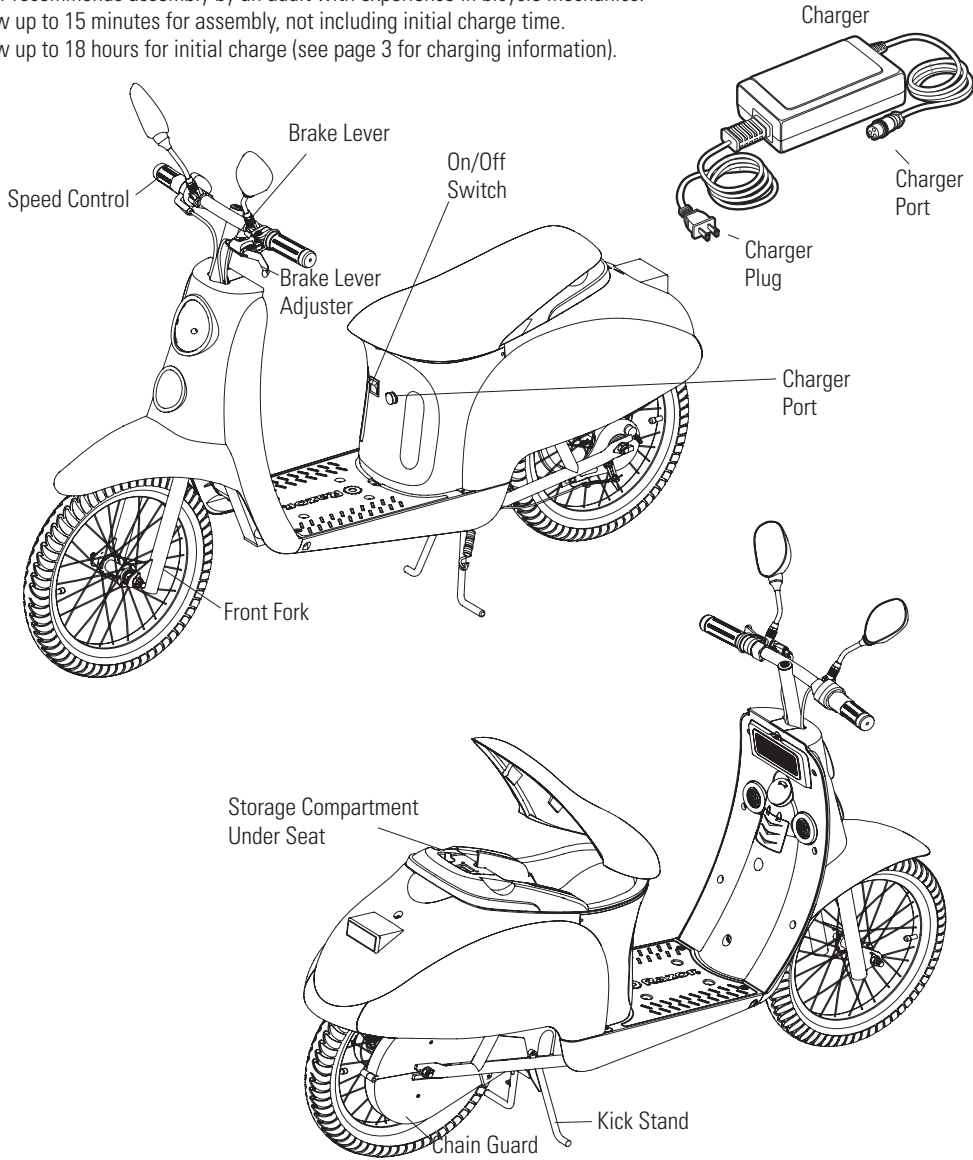

Required Tools

Some tools may be supplied; however, we recommend the use of mechanic's grade tools. Use the supplied tools only as a last resort.

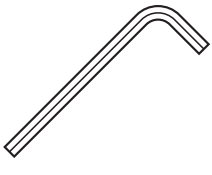

2.5mm, 3mm, 5mm, 6mm hexagonal key wrench (included)



14mm & 15mm wrenches (included)

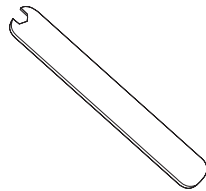

spoke wrenches (included)

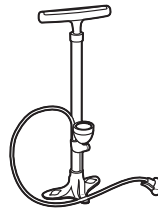

Bicycle-style tire pump for Schrader valve tires, with pressure gauge (not included)

Need Help? Visit our web site for updates and a list of authorized service centers at www.razor.com or call toll-free at 866-467-2967 Monday - Friday 8:00 AM - 5:00 PM Pacific Time.

ASSEMBLY AND SET-UP

❑ Charging the Battery

Your iMod may not have a fully charged battery; therefore it is a good idea to charge the battery prior to use.

- Initial charge time: 18 hours
- Recharge time: up to 12 hours depending on the level of depletion
- Run time: up to 40 minutes
- Average battery life: 250 charge/discharge cycles

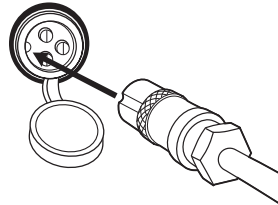
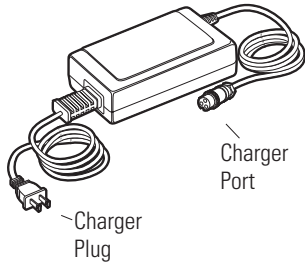

1 Turn off power switch before charging. Plug the charger into the charger port on the iMod.

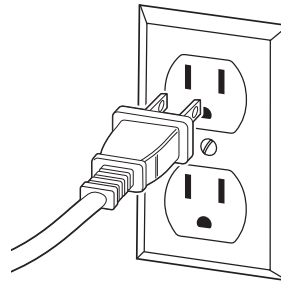

2 Plug the charger plug into a wall outlet.

⚠ WARNING:

Rechargeable batteries are only to be charged under adult supervision. Always disconnect your iMod from the charger before cleaning with liquid.

Note: If your charger does not look like the one illustrated, your unit has been supplied with an alternative charger. The specifications and charging procedure would not change.

The charger has a small window with one LED or two LEDs to indicate the charge status. Refer to the illustration on the charger unit for the actual "charging" and "charged" status indications for your model charger.

Chargers have built-in over-charge protection to prevent battery from being over-charged.

Be sure to properly align the groove on the charger input plug with the corresponding socket on the case; otherwise, no charging action will occur.

⚠ WARNING:

Failing to properly adjust and tighten the bolts that affix the handlebar can cause you to lose control and fall.

❑ Attaching the Handlebars



1 Remove the plastic cover end of the handlebars before inserting the handlebars. Insert handlebar assembly through front fairing and into fork until it stops. Raise to desired height keeping the handlebars and fairing aligned within the red arrows of the safety zone.

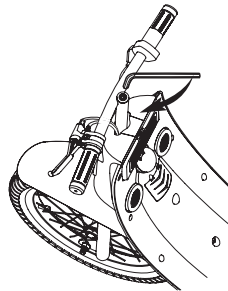

2 Tighten down the hexagonal bolt with the 6mm hexagonal key wrench.

❑ Attaching the Side View Mirrors

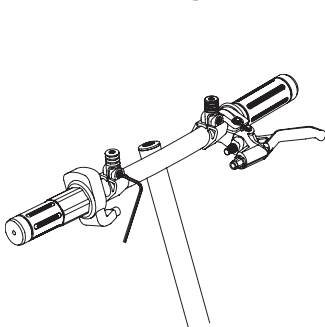

1 Adjust the rear view mirror socket into fixed place and tighten down half hexagonal bolts with 3mm hexagonal key wrench.

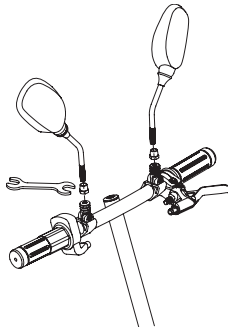

2 Insert the rear view mirror into sockets and tighten down the nuts with 14mm supplied wrench.

ASSEMBLY AND SET-UP

□ Attaching the Front Wheel

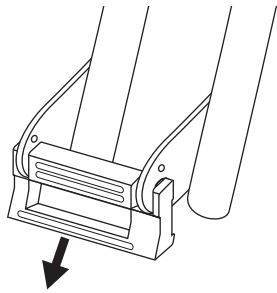

1 Remove the packing material from the front fork.

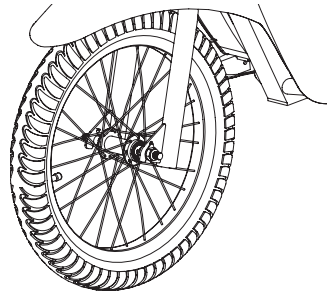

2 Insert the wheel into the front fork with the lock washers on the outside of the fork.

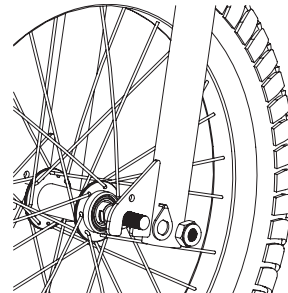

3 Insert the tab on the lock washer into the hole on the front fork and tighten the nuts with the supplied wrenches.

□ Testing the Brakes

To use the brake, squeeze the lever to increase the pressure on the brake. The brake lever is fitted with a cable adjuster to compensate for cable stretch and/or to fine-tune the lever movement to brake engagement. If brake is not engaging properly, follow instructions for adjusting the brakes below.

Check the Razor web site for any updates on the latest repair and maintenance procedures.

Turn power switch off before conducting any maintenance procedures.

□ Adjusting the Brakes

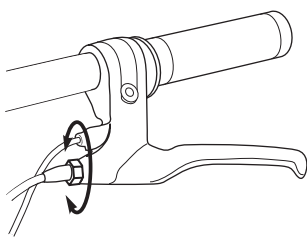

1 To adjust the play, thread the brake lever adjuster in or out 1/4 to 1/2 turn until the desired brake adjustment is attained. Most adjustments are complete at this step. If brake still needs further adjustment, proceed to step 2.

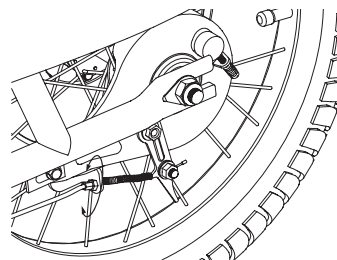

2 If the brake lever adjuster is threaded outward and the brake still has too much slack, use the rear brake adjuster for additional adjustment.

□ Checking Spoke Tension

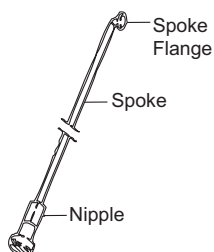

1 Verify spoke tension by grasping and shaking each spoke. Spoke should not be loose from hub. Look for any play between spoke flange and hub. Try to turn nipple using your fingers. You should not be able to turn any nipple by hand. Check all spokes and tighten if necessary.

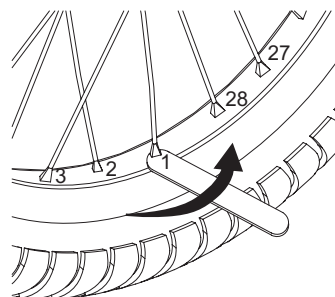
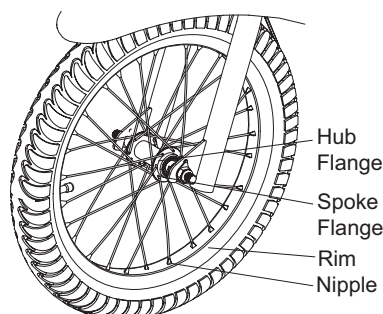

2 Start with spoke closest to tire valve and tighten each nipple. In sequence, exactly 1/4 to 1/2 turn. A single 1/4 to 1/2 turn may not be enough to bring the spokes into proper tension. Continue tightening all spokes no more than 1/2 turn in sequence until all spokes are tight.

⚠ WARNING: The brake is capable of skidding the tire and throwing an unsuspecting rider. Practice in an open area free from obstacles until you are familiar with the brake function. Avoid skidding to a stop as this can cause you to lose control or damage the rear tire.

Note: The brake lever contains a safety switch to stop the motor when the brake is applied. In an emergency, applying the brake will always stop the motor. Do not disable or replace this lever with anything other than a genuine Razor replacement part.

⚠ WARNING: Regularly check the spoke tension and retighten the spokes whenever loose. If you have any doubt, ask an experienced motorcycle or bicycle mechanic to inspect your spokes to determine if the spokes need tightening or adjusting.

Note: Tightening each nipple more than a 1/2 turn each can cause the wheel to become distorted and wobbly thus permanently damaging the wheel.

ASSEMBLY AND SET-UP

□ Installing batteries for speakers

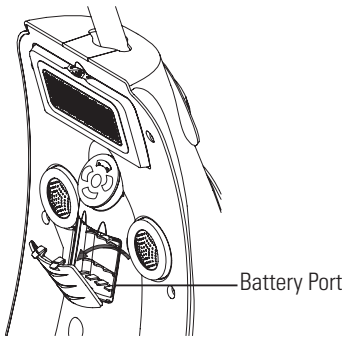

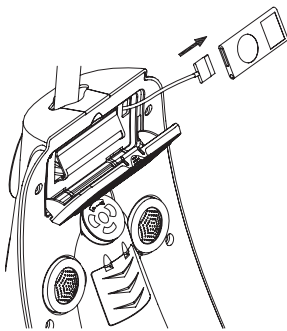

1 Open the battery port located under the power controller. Install 4AA batteries in the battery port. (Batteries not included)

□ Attaching your iPod *The iPod product name is used for identification purposes only. iPod is a registered trademark of Apple Inc.

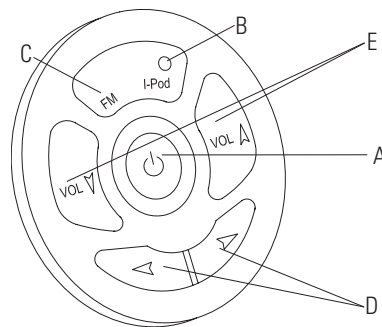

1 Open the iPod compartment and attach player to the 30 pin connector. Place the iPod in the compartment and securely fasten the cover.



- 2**
- A.) To turn on speakers, press the power button. 
 - B.) To turn on iPod function, press the iPod button.
 - C.) To listen to the FM Radio, press the FM button.
 - D.) FM stations are adjusted by the buttons on the bottom of controller.
 - E.) Volume adjuster ()

□ Inflating the Tires

Tires are inflated when shipped, but they invariably lose some pressure between the point of manufacturing and your purchase.

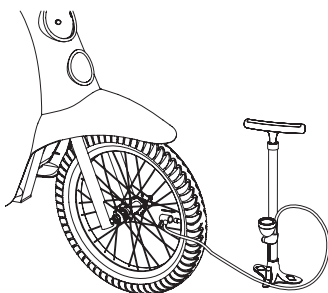

1 Using a bicycle style tire pump equipped for a Schrader-type valve, inflate the tires to the PSI indicated on the sidewall of the tires.

⚠ WARNING: It is your responsibility to secure your iPod player. Razor is not responsible for iPod damage.

Note: This product was designed to accommodate ONLY iPods in production as of January 2008. Not recommended for use with video iPod players.

Note: The pressurized air supplies found at gasoline stations are designed to inflate high-volume automobile tires. If you decide to use such an air supply to inflate your iMod tires, first make sure the pressure gauge is working, then use very short bursts to inflate to the correct PSI. If you inadvertently over-inflate the tire, release the excess pressure immediately.

REPAIR AND MAINTENANCE

Chain and Rear Tire Replacement

Tools required: Phillips screwdriver, 10mm wrench, two (2) 8mm wrenches, and two (2) 17mm wrenches.

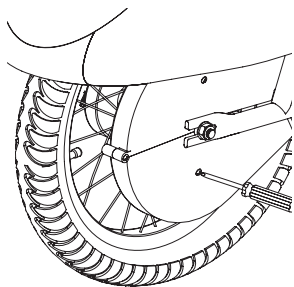

1 With a Phillips screwdriver, remove the screws that secure the chainguard. Remove chainguard.

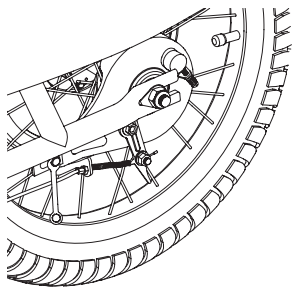

2 With a 8mm wrench, loosen the brake cable anchor and disconnect the cable.

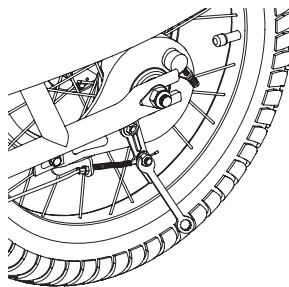

3 With two 10mm wrenches, loosen brake housing anchor and disconnect. Keep the spacer and washers together.

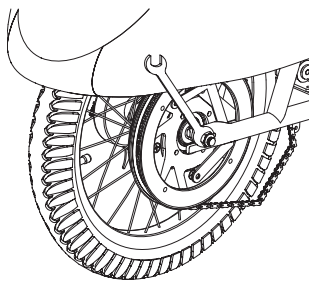

4 With two 15mm wrenches, loosen the axle. Push the wheel forward in the slots to loosen the chain.

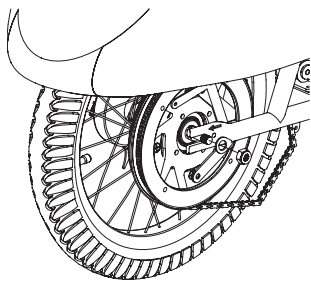

5 Pull the wheel out. Note the arrangement of the hardware sequence.
Note: Your hands will get greasy doing this.

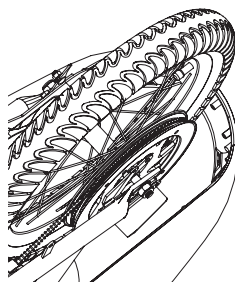

6 Install the new chain or wheel by slipping the chain around the axle. Slide the axle into the slots on the frame. Slide the wheel forward and maneuver the chain onto the rear sprocket, front sprocket and chain tensioner.

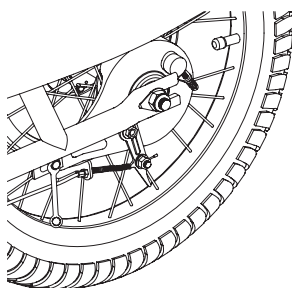

7 Tighten the brake housing anchor securely.

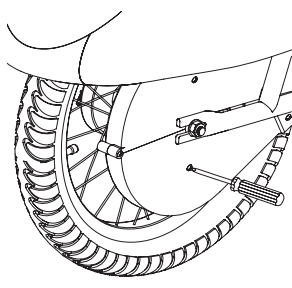

8 Re-attach the chain guard. Test ride and check. Readjust as needed.

REPAIR AND MAINTENANCE

□ Replacing the Fuse

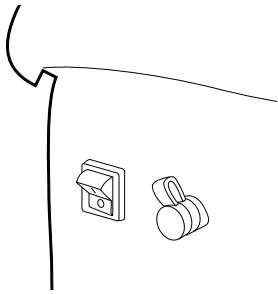

1 Make sure the power switch is turned OFF.

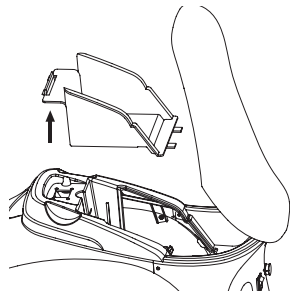

2 Lift up the seat and remove the storage compartment.

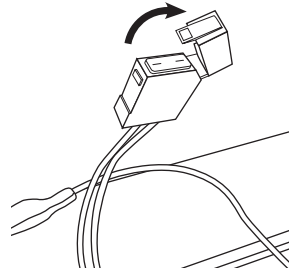

3 Locate fuse cover on top of battery assembly. Open the fuse cover to expose the fuse.

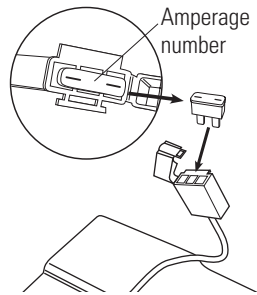

4 Remove the fuse and replace with a new one of equal amperage.

Note: Amperage rating is located on top of fuse. Fuse must be replaced with one of equal amperage.

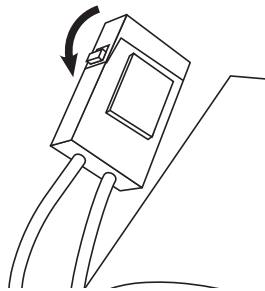

5 Close the fuse cover. Replace the storage compartment and close the seat cover.

⚠ WARNING:

To prevent shock or short circuit, please follow the instructions accordingly and do not skip or combine any steps.

□ Battery Care and Disposal

Do not store the battery in temperatures above 75° or below -10° F.



CONTAINS SEALED LEAD ACID BATTERIES. BATTERIES MUST BE RECYCLED.

Disposal: Your Razor product uses sealed lead-acid batteries which must be recycled or disposed of in an environmentally sound manner. Do not dispose of a lead-acid battery in a fire. The battery may explode or leak. Do not dispose of a lead-acid battery in your regular household trash. The incineration, land filling or mixing of sealed lead-acid batteries with household trash is prohibited by law in most areas. Return exhausted batteries to a federal or state approved lead-acid battery recycler or a local seller of automotive batteries. If you live in Florida or Minnesota, it is prohibited by law to throw away lead-acid batteries in the municipal waste stream.

□ Charger

The transformer/charger supplied with the iMod should be regularly examined for damage to the cord, plug, enclosure and other parts, and, in the event of such damage, the iMod must not be charged until it has been repaired or replaced.

Use ONLY with the recommended charger.

□ Replacement Parts

The most frequently requested replacement parts (wheels, tires, tubes, batteries and chargers) are available for purchase at some Razor retail partners or online at www.razor.com.

□ Repair Centers

For a list of authorized Razor repair centers:

- Check online at www.razor.com
- Send an e-mail or call 866-467-2967 for the center nearest you.

⚠ WARNING:

If a battery leak develops, avoid contact with the leaking acid and place the damaged battery in a plastic bag. Refer to the disposal instructions at left. If acid comes into contact with skin or eyes, flush with cool water for at least 15 minutes and contact a physician.

TROUBLESHOOTING GUIDE

Problem	Possible Cause	Solution
iMod does not run	Undercharged battery	Charge the battery. A new battery should have been charged for at least 18 hours before using the vehicle for the first time and up to 12 hours after each subsequent use. Check all connections. Make sure the charger is tightly plugged into the charging port on the iMod, and that the charger is plugged into the wall. Make sure power flow to the wall outlet is on.
	Charger is not working	You may check to see if your charger is working by using a volt meter or asking your local Razor authorized service center to test your charger for you.
	Loose wires or connectors	Check all wires and connectors to make sure they are tight.
iMod was running but suddenly stopped	Burned out fuse	The fuse will burn out and automatically shut off the power if the motor is overloaded. An excessive overload, such as too heavy a rider or too steep a hill, could cause the motor to overheat. Replace the fuse with a new one of equal amperage. Correct the conditions that caused the fuse to burn out and avoid repeatedly burning out fuse.
	Motor or electrical switch damage	Contact your local Razor authorized service center for diagnosis and repair.
Short run time (less than 30 minutes per charge)	Undercharged battery	Charge the battery. A new battery should have been charged for at least 18 hours before using the vehicle for the first time and up to 12 hours after each subsequent use. Check all wires and connectors. Make sure the battery connector is tightly plugged into the charger connector and that the charger is plugged into the wall. Make sure power flow to the wall outlet is on.
	Battery is old and will not accept full charge	Even with proper care, a rechargeable battery does not last forever. Average battery life is 1 to 2 years depending on iMod use and conditions. Replace only with a Razor replacement battery.
	Brakes are not adjusted properly	Refer to adjusting the brakes instructions on page 4.
iMod runs sluggishly	Driving conditions are too stressful	Use only on solid, flat, clean and dry surfaces such as pavement or level ground.
	Tires are not properly inflated	The tires are inflated when shipped, but they invariably will lose some pressure between the point of manufacturing and your purchase. Refer to instructions on page 5.
	iMod is overloaded	Make sure you do not overload the iMod by allowing more than one rider at one time, exceeding the 170 lb. maximum weight limit, going up a hill or towing objects behind the iMod. If the iMod is overloaded, the fuse will blow.
	Brakes are not adjusted properly	Refer to adjusting the brakes instructions on page 4.

TROUBLESHOOTING GUIDE

Problem	Possible Cause	Solution
Sometimes the iMod doesn't run, but other times it does	Loose wires or connectors	Check all wires around and all connectors to make sure they are tight.
	Motor or electrical switch damage	Contact your local Razor authorized service center for diagnosis and repair.
Charger gets warm during use	Normal response to charger use	No action required. This is normal for some chargers and is no cause for concern. If your charger does not get warm during use, it does not mean that it is not working properly.
iMod does not stop when applying the brake	Brakes are not adjusted properly	Refer to adjusting the brakes instructions on page 4.
iMod makes loud noises or grinding sounds	Chain adjustment is too tight or too loose	Refer to instructions on page 6 of this manual to properly adjust chain and sprocket.
	Chain is too dry	Apply a lubricant such as 3 in 1™ or Tri-Flow™ to the chain.

Need Help? Visit our web site for updates and a list of authorized service centers at www.razor.com or call toll-free at 866-467-2967 Monday - Friday 8:00 AM - 5:00 PM Pacific Time.

POCKET MOD IMOD PARTS

Keep your Pocket Mod running for years with genuine Razor parts. Visit our web site or e-mail us for more information on spare part availability. (Specifications subject to change without notice.)

1	Handlebar Grip (Right/Left)	8	Front Wheel Complete
2	Brake Lever Assembly	9	Front Fork
3	Side View Mirror (Right/Left)	10	Base Fairing
3-1	Side View Mirror Socket	11	Motor (24V 350W)
4	Handlebar	12	Kickstand
5	Twist Grip Throttle	13	Rear Wheel Complete
5-1	Sleeve	14	Chain
6	Front Fairing Cover	15	Chain Guard
6-1	iPod Case	16	Battery (2-12V/10AH) w/Fuse
6-2	Speaker Cover	17	Control Module
6-3	Audio PC Board	18	Front Seat Fairing
6-4	Audio Cover	19	On/Off Switch
6-5	iPod Plug	20	Charger Port w/Wires
6-6	Control Board	21	Seat Fairing
6-7	Speaker	22	Rear Fairing w/Trim (Right/Left)
6-8	Battery Cover	23	Bottom Cover of Storage Compartment
7	Fairing w/Headlamp Cover	24	Storage Compartment

POCKET MOD IMOD PARTS

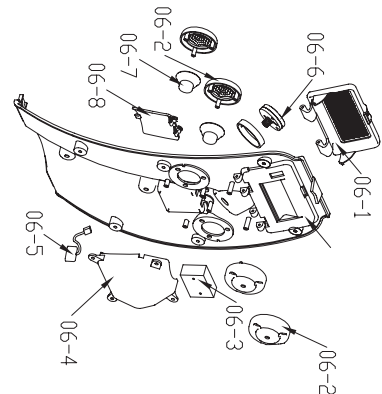
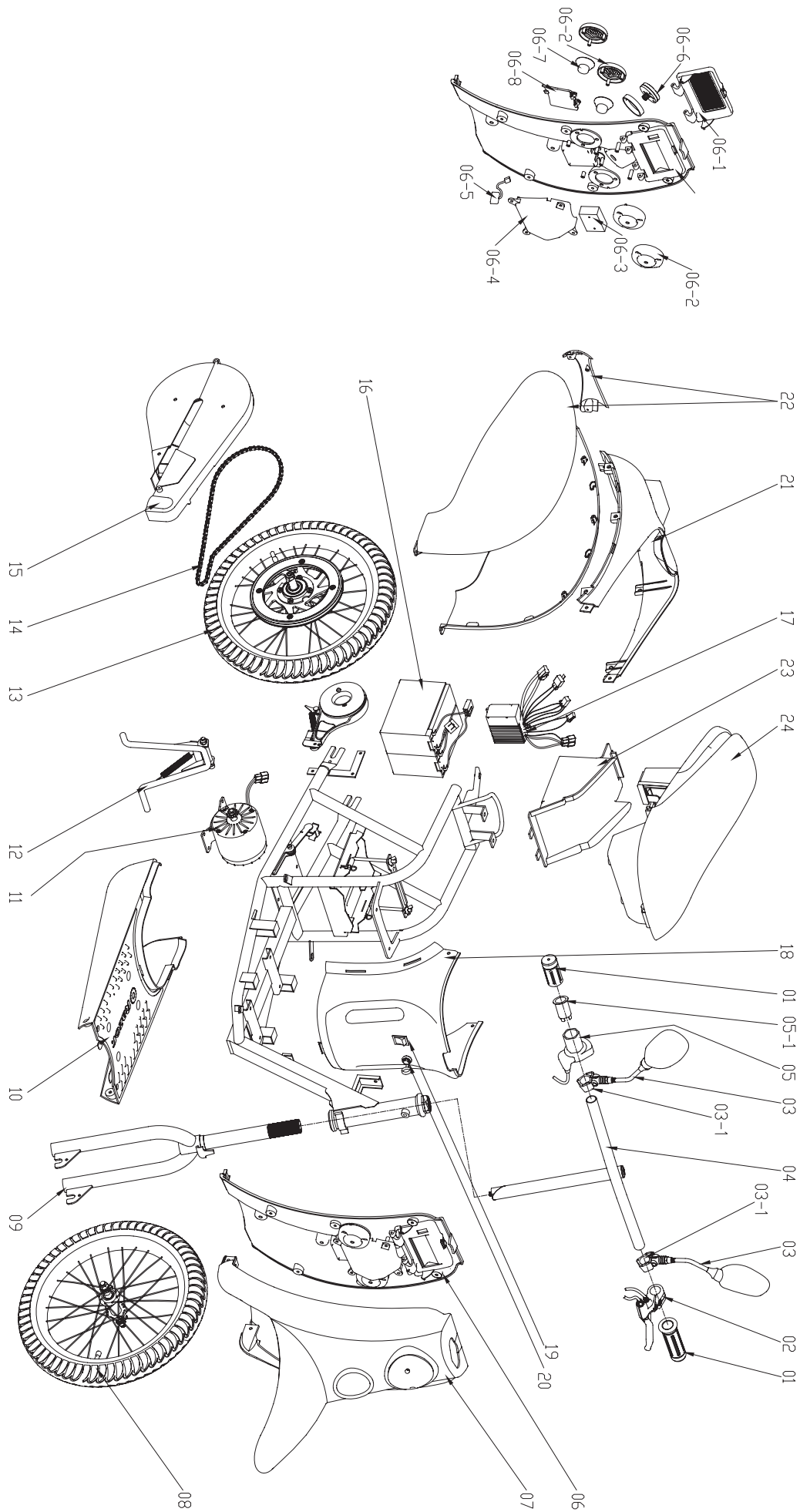

SB 1918 (CALIFORNIA) DECLARATION

YOUR INSURANCE POLICIES MAY NOT PROVIDE COVERAGE FOR ACCIDENTS INVOLVING THE USE OF THIS SCOOTER/ELECTRIC VEHICLE. TO DETERMINE IF COVERAGE IS PROVIDED, YOU SHOULD CONTACT YOUR INSURANCE COMPANY OR AGENT.

SAFETY REMINDERS

PRE-RIDE CHECKLIST



Loose Parts

There should not be any unusual rattles or sounds from loose parts or broken components. If you are not sure, ask an experienced mechanic to check.



Brake

Check the brake for proper function. When you squeeze the lever, the brake should provide positive braking action. When you apply the brake with the speed control on, the brake cut-off switch will stop the motor.



Frame, Fork and Handlebars

Check for cracks or broken connections. Although broken frames are rare, it is possible for an aggressive driver to bash into a curb or wall and wreck and bend or break a frame. Get in the habit of inspecting yours regularly.



Tire Inflation

Periodically inspect the tires for excess wear and replace as required, and regularly check the tire pressure and re-inflate as necessary. If you get a flat tire, the inner tube can be patched or a new tube can be purchased from Razor or an authorized repair center.



Safety Gear

Always wear proper protective equipment such as an approved safety helmet. Elbow pads and kneepads are recommended. Always wear shoes, never drive barefooted or in sandals, and keep shoelaces tied and out of the way of the wheels, motor and drive system.



DO NOT RETURN TO STORE

Do not use this vehicle for the first time until you have inflated the tires to the correct PSI and charged the battery for at least 18 hours.

Failure to follow these instructions may damage your vehicle and void your warranty.

WARRANTY

Razor Limited Warranty

The manufacturer warrants this product to be free of manufacturing defects for a period of 90 days from date of purchase. This Limited Warranty does not cover normal wear and tear, tires, tubes or cables, or any damage, failure or loss caused by improper assembly, maintenance, or storage or use of the Razor Pocket Mod.

This Limited Warranty will be void if the product is ever

- used in a manner other than for recreation;
- modified in any way;
- rented.

The manufacturer is not liable for incidental or consequential loss or damage due directly or indirectly to the use of this product.

Razor does not offer an extended warranty. If you have purchased an extended warranty, it must be honored by the store at which it was purchased.

For your records, save your original sales receipt with this manual and write the serial number below.

Item Number:

iMod™

15130699

Need Help? Visit our web site for updates and a list of authorized service centers at www.razor.com or call toll-free at 866-467-2967 Monday - Friday 8:00 AM - 5:00 PM Pacific Time.

Printed in China for:
Razor USA LLC
PO Box 3610
Cerritos, CA 90703

Copyright © 2003 - 2008 Razor USA LLC. All rights reserved. RAZOR and the Razor Logo Design are among the registered trademarks of Razor USA LLC in the United States and/or select foreign countries.