

# SPD-36500BLDC 36 Volt 500-600 Watt 30 Amp Brushless DC Motor Controller





Operating Voltage: 36 Volts DC

Power: 600 Watts (Works with 500-600 Watt Brushless DC Motors)

Current Limit: 30 Amps (30 Amp Maximum Current Output)

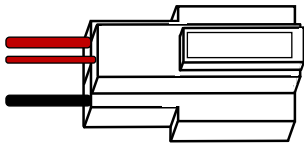
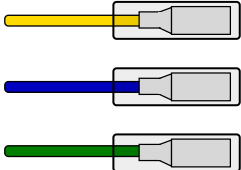
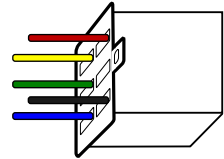
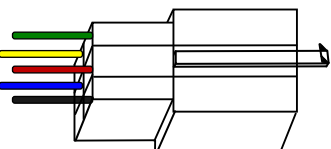
Low Voltage Protection: 31.5 Volts

Compatible with 120 Degree and 60 Degree Motor Phases

Input Power and Power Switch Wires		<p>Thick Red Wire to Battery Positive +          *Thin Red Wire to Power Switch Contact          Black Wire to Battery Negative -          *When the thin red wire makes contact with Battery Positive wire the power is on.</p>
Motor Phase Wires		<p>Yellow to Yellow Motor Phase U Wire          Blue to Blue Motor Phase V Wire          Green to Green Motor Phase W Wire</p>
Motor Hall Sensor Wires		<p>Red to Red Motor Hall Wire +5V          Black to Black Motor Hall Wire Negative -          Yellow to Yellow Motor Hall U Wire          Green to Green Motor Hall W Wire          Blue to Blue Motor Hall V Wire</p>
Throttle and Motor Power Output Wires		<p>Green 1-4 Volt Throttle Signal Input          Red +5 Volt Throttle Output          Black Throttle Negative -          † Yellow +4.9V Through +8.8V Output          † Blue +2.4V Through +6.5V Output          Power output wire Voltage changes depending on throttle position.</p>
* Reverse Wires		<p>† Yellow to Reverse Switch Contact          † Yellow to Reverse Switch Contact</p>
** Speed Limiter Wires		<p>† Black to Speed Limit Switch Contact          † Black to Speed Limit Switch Contact</p>
*** Speedometer Wire		<p>† Pink to Speedometer Positive + Input</p>

Only the Input Power and Power Switch Wires, Motor Phase Wires, Motor Hall Sensor Wires, and Red-Green-Black Throttle Wires need to be connected for the controller to operate. The connection of all other wires are optional.

† Optional Connections: These wires do not need to be connected for the controller to operate.

\* The Power Switch must be turned off and then on for reverse to activate.

\*\* The Speed Limiter wires reduce motor speed by 50% when connected together.

\*\*\* The Speedometer wire outputs 0 Volts DC an zero motor RPM and 24 Volts DC at full motor RPM.