



## Parent and Rider manual

# STOP!

### DO NOT RETURN TO STORE

**This product cannot be returned  
for a refund after it has been  
unpacked and used.**

**Call us Toll-Free  
at 1-866-204-9737 or  
for assistance and information  
from our trained staff.**

**For product related questions  
or customer service needs please  
email [info@hypertoys.com](mailto:info@hypertoys.com)**

**VISIT US ONLINE@  
[www.hypertoys.com](http://www.hypertoys.com)**

**CAUTION! CHARGER IS A ELECTRONICALLY OPERATED PRODUCT:  
Not recommended for children under 13 years of age. As with all  
electric products, precautions should be observed during handling  
and use to prevent electric shock.**



**WARNING: USE AT YOUR OWN RISK. ADULT SUPERVISION IS REQUIRED.**  
THIS IS A POWERFUL TOY AND IS NOT INTENDED FOR RIDERS UNDER THE AGE OF 13.

Do not discard this owner's manual. Refer to the manual for important instructions before operating and to progress in skill.

No more than 1 rider at a time. Do not exceed 139lbs (63kgs) rider weight.

Do not allow riders under the age of 13 years old to use this product. Adult supervision is required.

Always wear shoes and proper protective gear, such as ANSI, SNELL, or ASTM approved helmets. Elbow and knee pads are also recommended.

Battery life may be reduced in extreme temperatures or with a maximum weight load.

Use only in safe controlled areas, not on public streets, or near motor vehicles.

Do not ride at night or in low visibility conditions.

Steep, rough, uneven, or wet surfaces can increase risk to the rider.

Be sure to check local regulations to understand how and where it is allowed to use this product.

**CONTAINS SEALED LEAD-ACID BATTERY. MUST BE RECYCLED OR DISPOSED OF SAFELY.**

FOR ASSISTANCE WITH  
YOUR ASSEMBLY CALL:  
**1-866-204-9737 TOLL FREE**

**HYPER TOY  
CO**

Please read this manual before assembly.

Please save your Receipt for  
Warranty Registration and save this  
Manual for directions on assembly  
and operation.

24 Volt Rechargeable Battery Powered Ride-On Vehicle

**HYPER**  
**HFR350**

AGE **13+**  
MAX WEIGHT  
139 LBS



**24** VOLT  
ELECTRIC

MAX WEIGHT: 139 LBS (63 KGS)  
MAX RIDERS: 1  
MAX SPEED: 14 MPH (22 KPH)  
FORWARD ONLY  
EASY TWIST THROTTLE  
24 VOLT BATTERY AND CHARGER INCLUDED  
WORKS ON HARD SURFACES AND GRASS  
CONTAINS LEAD ACID BATTERY

**WARNING:**  
Assembly by an adult.

[www.HyperToys.com](http://www.HyperToys.com)

FOR ASSISTANCE WITH  
YOUR ASSEMBLY CALL:  
**1-866-204-9737 TOLL FREE**

1

**HYPER** TOY  
CO

# Table of Contents

<b>Important Information</b>	<b>2</b>
<b>Safety, Warnings &amp; Cautions</b>	<b>4</b>
<b>Riding Safely</b>	<b>5</b>
<b>Pre-Assembly Parts &amp; Tools</b>	<b>6</b>
<b>Battery Charging &amp; Installation</b>	<b>7</b>
<b>Assembly Instructions</b>	<b>8</b>
<b>Maintenance &amp; Repair</b>	<b>9-13</b>
<b>Operation</b>	<b>14</b>
<b>Vehicle Care &amp; Pre-Riding Check</b>	<b>15</b>
<b>Troubleshooting</b>	<b>16</b>
<b>Limited Warranty</b>	<b>17</b>
<b>Product Registration</b>	<b>19</b>



## Important Information

- **ADULT ASSEMBLY REQUIRED!**
- The battery must be charged for **12 hours** before the vehicles first use. To start charging the battery before starting assembly, see Battery Charging and Installation information. See Battery Charging instructions on pg. 7 of this manual.
- Use of any other 24 Volt battery or charger may damage the vehicle and will void the warranty. Please contact Customer Service at **1-866-204-9737** for replacement parts.
- Instruct children on safe operation and driving rules before they take their first ride:
  - Do not allow more than one rider at a time
  - Sit in the proper position on the vehicle when riding
  - Always wear shoes when riding the vehicle
  - Do not allow other children near the vehicle when riding
  - Do not place your hands, feet, or any part of your body, clothing, or other articles near moving parts while the vehicle is in operation
- Instruct children to bring the vehicle to a complete stop before switching between forward and reverse.
- Do not overload the vehicle or exceed the maximum weight capacity of 139lbs (63kgs).  
For all questions please contact us at **1-866-204-9737 Toll Free.**
- **Please read this manual completely** for operation and safety information before using the toy. Keep these instructions for future reference.

FOR ASSISTANCE WITH  
YOUR ASSEMBLY CALL:  
**1-866-204-9737 TOLL FREE**





## **WARNING: Electrical Hazard**

**RISK OF FIRE. Do not bypass. Replace only with 30A fuse.**

- Only use a Hyper Toy Co. 24V lead-acid battery.
- Only use a Hyper Toy Co. 24V battery charger.
- Never modify the electrical system. Changes could cause a fire resulting in serious injury or death, and could also ruin the electrical system.
- Never lift or carry the battery by the wires or connectors. This can damage the battery and possibly cause a fire resulting in serious injury or death. Always use the battery holder to carry it.
- The battery should be handled by adults only. The battery is heavy and contains sulfuric acid (electrolyte). Always use the attached battery handle for carrying.
- Children should never be allowed to charge the battery. Charging the battery must be done by adults only. The electricity involved in charging the battery could injure a child.
- The motors will get hot, handle carefully.
- Each time you charge the battery check the battery, charger, and their connectors for excessive wear or damage. Do not use the charger or the battery if damage or excessive wear is detected until you have replaced the worn or damaged parts.
- Carefully read the safety instructions about the battery.

## **WARNING: Charger**

Changes or modifications to this unit not expressly approved by the party responsible for compliance could void the user's authority to operate the equipment.

**NOTE:** This equipment has been tested and found to comply with the limits for a Class B digital device, pursuant to Part 15 of the FCC Rules. These limits are designed to provide reasonable protection against harmful interference in a residential installation. This equipment generates, uses and can radiate radio frequency energy and, if not installed and used in accordance with the instructions, may cause harmful interference to radio communications.

However, there is no guarantee that interference will not occur in a particular installation. If this equipment does cause harmful interference to radio or television reception, which can be determined by turning the equipment off and on, the user is encouraged to try to correct the interference by one or more of the following measures:

- Reorient or relocate the receiving antenna.
- Increase the separation between the equipment and receiver.
- Connect the equipment into an outlet on a circuit different from that to which the receiver is connected.

Consult the dealer or an experienced radio/TV technician for help.

## **CAUTION:**

- When fully unassembled, this package contains small parts. Adult assembly is required.
- Use the charger in dry ventilated areas only.
- Any components or parts of this product should be maintained or repaired in accordance with Hyper Toy's specifications, using only Hyper Toy's authorized replacement parts, and should not be modified from the Hyper Toy's original design and configuration.

## **WARNING: Riding Hazard**

To reduce the risk of injury adult supervision is required

- Never use in roadways or near motor vehicles
- Never use on or near steep inclines or steps
- Never ride near swimming pools or other bodies of water
- Always wear shoes while riding
- Never allow no more than 1 rider at a time
- Follow the 139lbs (63kgs) weight

FOR ASSISTANCE WITH  
YOUR ASSEMBLY CALL:  
**1-866-204-9737 TOLL FREE**

### **⚠️ WARNING: Adult Supervision Required**

- Always Teach Safety First.
- While most children can develop the physical skills necessary to operate this vehicle, it is important to remember that they do not yet have mature judgment skills. Children should never be allowed to ride this vehicle without adult supervision. Before any child rides this vehicle an adult must evaluate the child's skill levels and abilities to operate the vehicle safely. Even after instruction hazards are not always anticipated or recognized by children. So before any child operates the vehicle teach them appropriate safety rules.
- THERE IS NO SUBSTITUTE FOR DIRECT ADULT SUPERVISION.

### **⚠️ WARNING: Safe Riding Rules**

To reduce the risk of injury adult supervision is required

- Always sit on the vehicles designated seat only.
- Always wear boots or shoes when riding this vehicle.
- Never allow a child under age of 13 years old to operate this vehicle.
- Never have more than one rider at a time operating this vehicle.
- Do not attempt to perform racing, stunt riding, or other maneuvers, which may cause loss of control, or may cause uncontrolled rider actions or reactions.
- Never use headphones, a cell phone or text while operating this vehicle.
- Do not exceed this vehicles rider weight limit of 139 lbs (63 kg).
- Do not operate this vehicle on the surfaces with water, sand, gravel, dirt, leaves, and other debris. Wet weather impairs traction, braking, and visibility.
- Avoid sharp bumps, drainage grates, and sudden surface changes.
- Do not operate this vehicle on or near drop-offs, obstructions, swimming pools or other bodies of water.
- Do not operate this vehicle in roadways, on the street or near moving vehicles.
- Do not operate this vehicle on or near steep inclines or steps. Use on generally level ground only.
- Do not operate this vehicle in the dark as unexpected obstacles could cause an accident.
- Do not operate this vehicle on slopes, this vehicle may accelerate or roll backwards at a unsafe speed.
- Do not allow hands, feet, hair, body parts, clothing, or similar articles to come in contact with moving parts, wheels, drive-train, or chain while this vehicles motor is running.
- Do not operate this vehicle near flammable vapors such as gasoline, paint thinner, acetone, liquid wax, etc. Electrical components can produce an internal spark when first turned on or off. Using this vehicle near flammable liquids or vapors could cause an explosion or fire resulting in serious injury or death.
- User need to follow Hyper Toy's recommendations and instructions, as well as comply with all laws and ordinances.
- Pregnant women, and people with heart conditions, and people with head, back, or neck ailments, or prior surgeries to those areas of the body shall be cautioned not to ride; People with mental or physical conditions that may make them susceptible to recognize, understand, and perform all of the safety instructions and to be able to assume the hazards inherent in unit use do not use this product.
- Before each cycle of operation, user shall do preparation checks specified by Hyper Toys.

# Parts

## Pre-assembly Part and Tool Identification

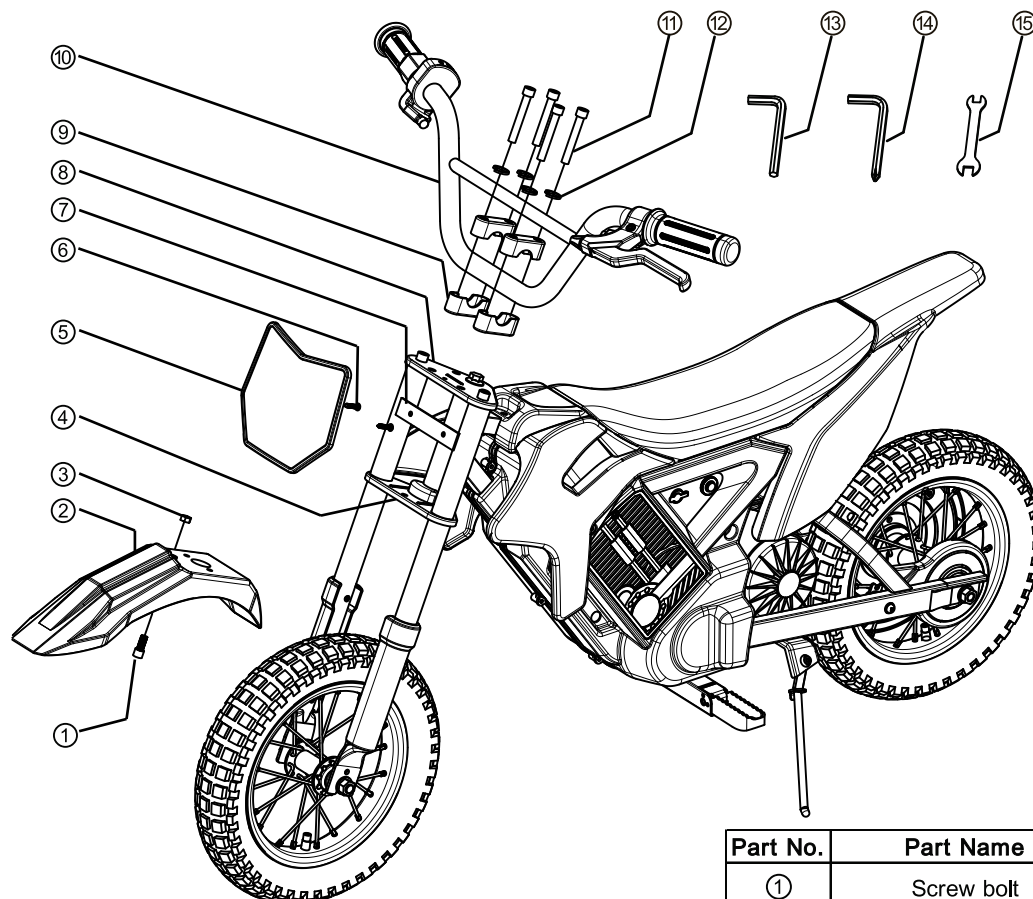

Bolt Size	Torque Specifications
5mm	3.69 ft-lbs (5 N-m)
6mm	7.38 ft-lbs (10 N-m)
8mm	15.48 ft-lbs (21 N-m)
10mm	25 ft-lbs (34 N-m)
12mm	39 ft-lbs (53 N-m)

Part No.	Part Name	Specification	Quantity
①	Screw bolt	M6 x16	1 pc
②	Front fender		1 pc
③	Nut	M6	1 pc
④	Down triangular plate	Assembled	1 pc
⑤	Front number plate		1 pc
⑥	Self screw	ST4.2 x 8	2 pcs
⑦	Front number plate frame	Assembled	1 pc
⑧	Top triangular plate	Assembled	1 pc
⑨	Handlebar clamp		4 pcs
⑩	handlebar set	Assembled	1 set
⑪	Screw bolt	M8 x 55	4 pcs
⑫	Spring washer	φ8.2 x φ12 x 1.7	4 pcs
⑬	Allen key	6mm	1 pc
⑭	Allen key with screwdrive	5mm	1 pc
⑮	Wrench	8/10mm	1 pc

FOR ASSISTANCE WITH  
YOUR ASSEMBLY CALL:  
**1-866-204-9737 TOLL FREE**

# Battery

## Charging and Care

### Charging Battery

**⚠ CAUTION:** The battery and charger are not toys. All battery charging must be done by an adult.

**NOTE:** Your HYPER TOY COMPANY electric motorcycle may not have a fully charged battery; therefore you must charge the battery prior to first use. The initial charge time is 12 hours. Recharge time is up to 12 hours but never over 24 hours.

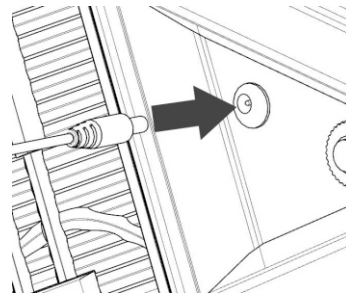
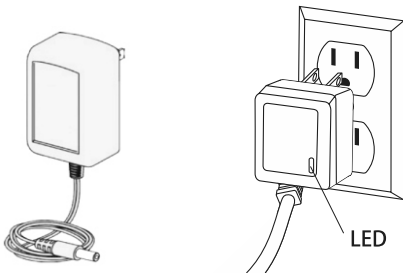

1. Plug the charger plug into wall outlet. The light on the charger should be green. **NOTE:** If green light (LED) does not turn on, try a different outlet.

2. Make sure the power switch is in the OFF position. Plug the charger into the charger port on the product. The light on the charger should turn red during charging. The light will turn green when the charging is complete.

### Battery Care

- First Charge Time: 12 hours.
- Recharge Time: 12 hours, even if the light turns green.
- Recommended maximum charging time is 24 hours.
- Always charge the battery immediately after riding.
- Fully charge battery before storing for long periods of time.
- Unplug charger from the wall outlet when not in use.
- Failure to recharge battery periodically may result in a battery that will not accept a charge.
- Always turn OFF electric motorcycles ON/OFF switch while not in use. Leaving the power switch on for an extended period of time may damage the battery.
- Never store this vehicle in freezing or below freezing temperatures, this will damage the battery.
- Run time: Up to 30 min. Run time may vary depending on riding conditions, rider weight, climate, and/or proper maintenance.
- Constant stopping and starting may shorten ride time.
- Proper maintenance and usage of the unit will determine Battery Life.

### Battery Disposal

- Your vehicle's battery is a sealed lead-acid battery. You must recycle or dispose of it in an environmentally sound manner.
- Never dispose your battery in the regular, household trash. The incineration, land-filling, or mixing of a sealed lead-acid battery with your household trash is prohibited by law in most areas.
- Make sure to return exhausted batteries to a federal or state approved lead-acid battery recycler or contact Hyper Toy Company at 1-866-204-9737.
- Always remove exhausted batteries from your toy. Dispose of dead batteries properly; never burn or bury them.
- **Contact Customer Service at 1-866-204-9737 for Replacement Battery and Receive Free Shipping with Purchase of Battery.**
- To locate a battery service center, contact your local waste management company.
- Do not mix old and new batteries.
- Do not mix alkaline, standard(carbon-zinc) or rechargeable(nickel-cadmium) batteries.

FOR ASSISTANCE WITH  
YOUR ASSEMBLY CALL:  
**1-866-204-9737 TOLL FREE**

# Assembly Instructions

**⚠ WARNING:** DO NOT USE OTHER PRODUCTS WITH YOUR HYPER MOTORCYCLE. The HYPER TOY COMPANY electric motorcycle has been built to certain HYPER TOY COMPANY design specifications. The original equipment supplied at the time of sale was selected on the basis of its compatibility with the frame, fork and all other parts. Aftermarket products may not be compatible and will void your warranty.

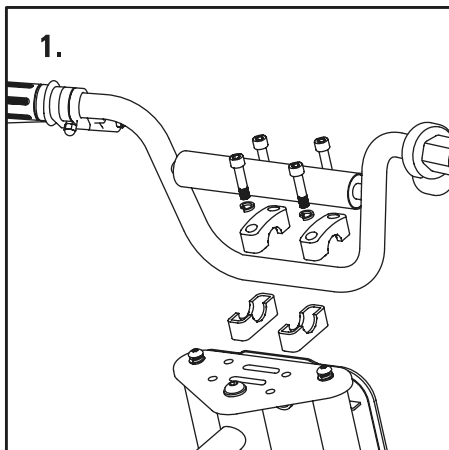

Take out handlebar clamps, bolts, and spring washers from toolkit and place handlebars in handlebar clamps as shown in drawing.

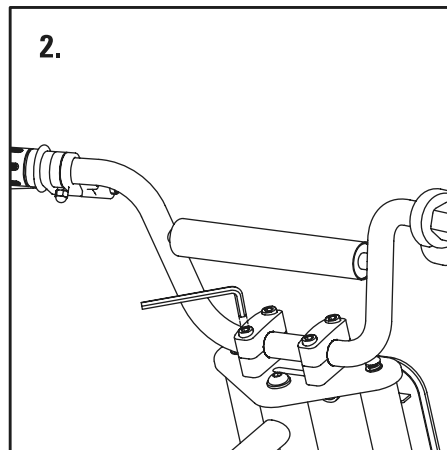

Mount the handlebars to align vertically, on the same angle as the fork and tighten the bolts using a 6 mm Allen wrench. See pg. 6 for torque specifications. When properly tightened, the handlebars should not move forward or backward with force applied.

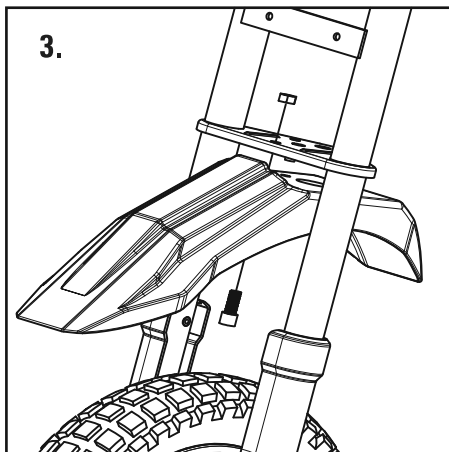

Align front fender with the hole in the fork clamp and insert the bolt. Tighten securely using a 10mm wrench and 5mm allen wrench.

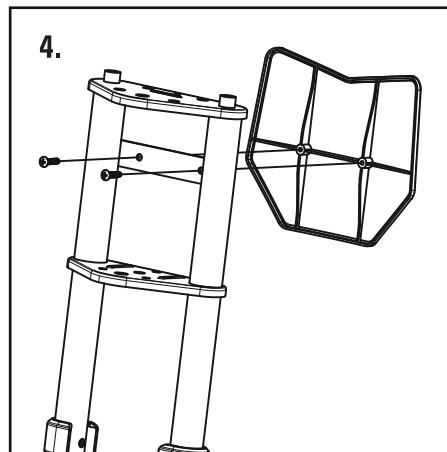

Turn handlebars to the left and right to install the front number plate with the provided 2 screws and screwdriver.

FOR ASSISTANCE WITH  
YOUR ASSEMBLY CALL:  
**1-866-204-9737 TOLL FREE**

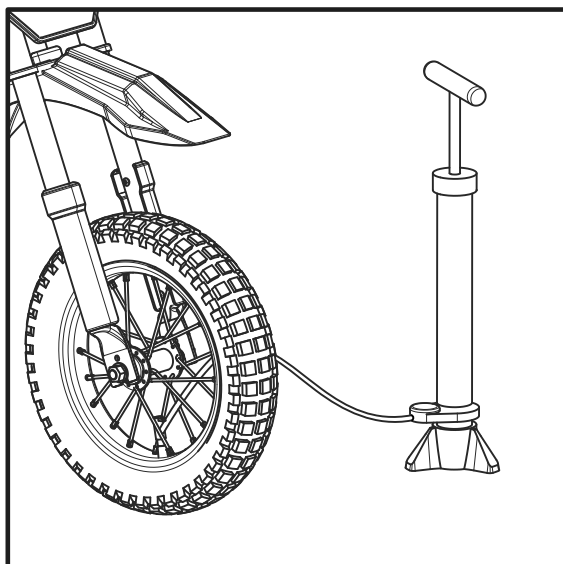

## Inflating the Tires

Tires are inflated when shipped, but they invariably lose some pressure between the point of manufacturing and your purchase. Inflate the tires to the correct PSI before first time use.

Lower air pressure can result in a shorter ride time. Periodically check both tires. Re-inflate when needed.

Using a bicycle tire pump equipped for a Schrader valve, inflate both tires to the PSI indicated on the sidewall of the tire.

Do not over inflate the tires this could cause wheel or tire damage.

## Spoke Tension

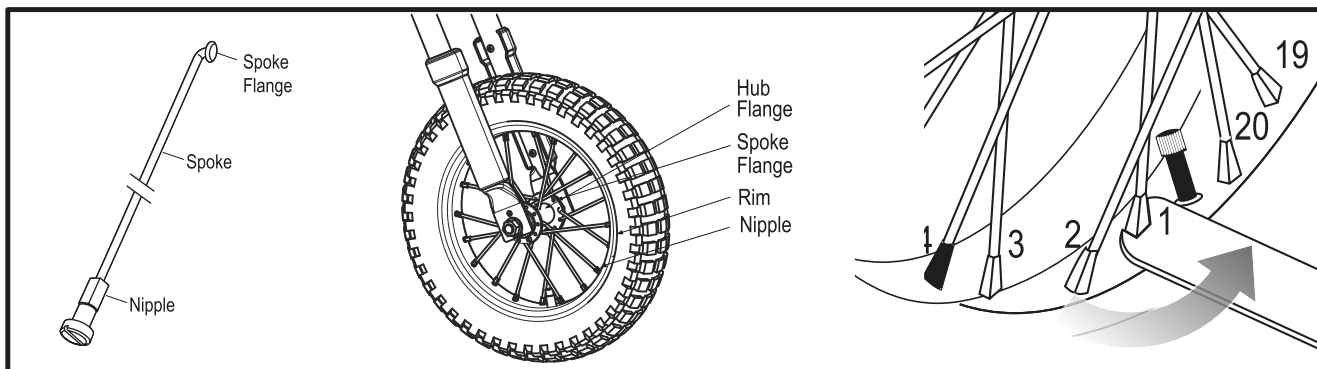

Check the spoke tension by grasping and shaking each spoke. Look for any play between the spoke flanges where it mates with the hub. Try to turn the nipple using your fingers. You should not be able to spin any nipple by hand.

If one or more spokes is loose, all spokes should be checked and tightened with a spoke tightener. All spokes should be checked regularly to assure none are loose or broken.

Start with spoke closest to the tire valve stem and tighten each nipple, in sequence, exactly 1/4 to 1/2 turn. A single 1/4 to 1/2 turn may not be enough to bring the spokes into proper tension. Continue tightening all spokes no more than 1/2 turn in sequence until all spokes are tight.

**NOTE:** More than a 1/2 turn each can cause the wheel to become distorted and wobbly, thus permanently damaging the wheel.

FOR ASSISTANCE WITH  
YOUR ASSEMBLY CALL:  
**1-866-204-9737 TOLL FREE**

**HYPER** TOY  
CO

## Testing the Brake

Always turn power switch "OFF" before beginning repair or maintenance:

To test the brake squeeze the brake lever. The brake lever is fitted with a cable adjuster to compensate for cable stretch and/or to fine-tune the lever movement to engage the brake. If brake is not engaging properly, follow instructions for adjusting the brake outlined below.

## Brake Adjustment

Fig. 1

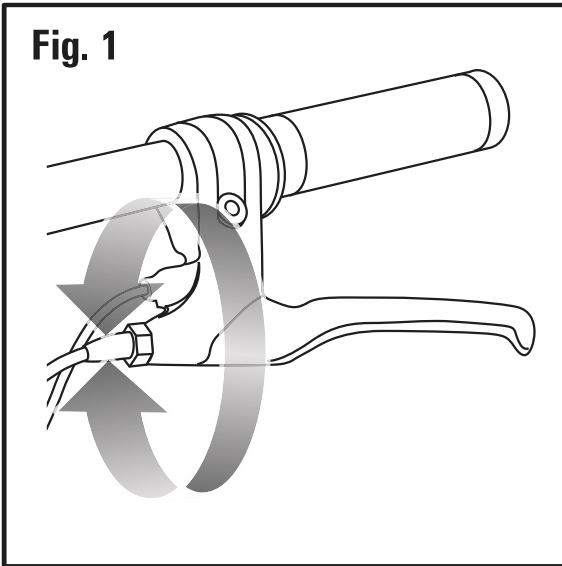

1. To test the brake squeeze the brake lever. The brake lever is fitted with a cable adjuster to compensate for cable stretch and/or to fine-tune the lever movement to engage the brake. If brake is not engaging properly, follow instructions for adjusting the brake outlined below.

**NOTE:** The brake lever contains a safety switch to cut power to the motor when the brake is applied. In an emergency, applying the brake will always stop the product from moving. Do not disable or replace this lever with anything other than a Hyper Toy Company replacement part. Call customer service at 1-866-204-9737.

Fig. 2

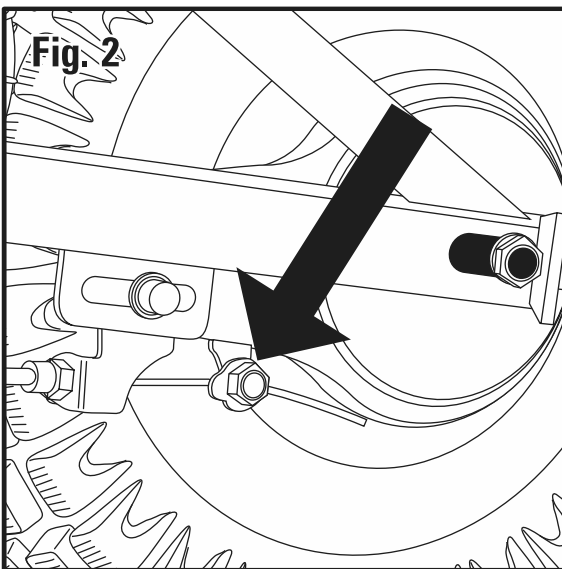

2. If the brake has too much slack, use a **10 mm wrench** to loosen the brake anchor cable for additional adjustment and re-tighten.

**WARNING!** The brake is capable of causing the electric motorbike to skid the tire, causing a loss of control. Practice in an open area free from obstacles until you are familiar with the brake function. Avoid skidding to a stop as this can cause you to lose control or damage the rear tire.

FOR ASSISTANCE WITH  
YOUR ASSEMBLY CALL:  
**1-866-204-9737 TOLL FREE**

# Repair and Maintenance

## Chain and Rear Wheel

**Tools Required:** Phillips Screwdriver, 10 mm Wrench, two (2) 8 mm Wrenches, and two (2) 15 mm Wrenches.

1.

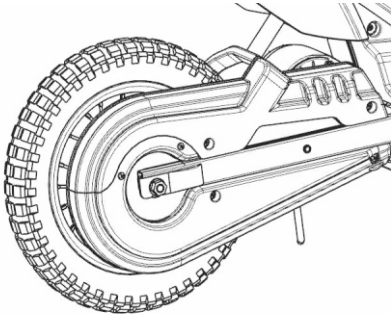

Using a Phillips screwdriver remove the screws on chain guard and remove.

2.

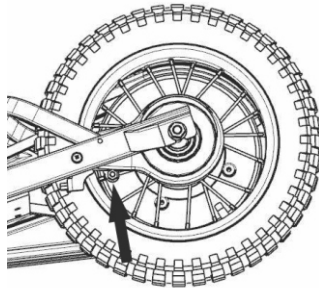

With a 10 mm wrench, loosen the brake cable anchor bolt and disconnect the cable.

3.

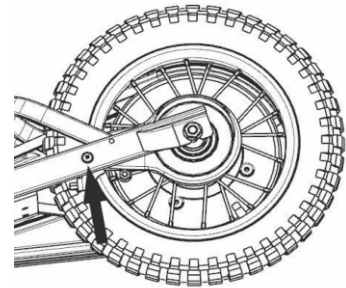

With two (2) 8 mm wrenches remove the cable guide bracket from the frame and brake plate. Keep the spacer and washers together.

4.

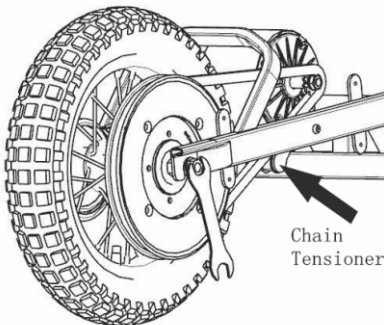

With two (2) 15 mm wrenches, loosen the axle. Push the chain tensioner down to loosen the chain and remove wheel.

5.

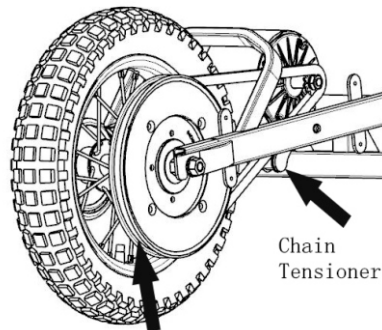

Install the chain onto the rear wheel sprocket. Slip wheel axle into the frame slots. Push the chain tensioner down to create slack in chain. Hand tighten rear axle locknuts.

6.

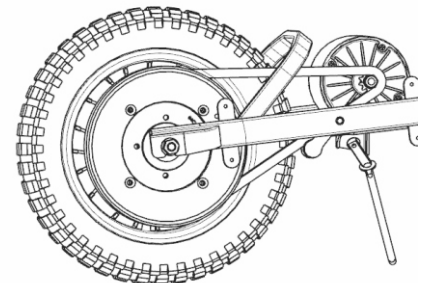

Verify chain is properly installed on each sprocket and the chain tensioner is correctly positioned at the bottom of the chain. Check and maintain the motorcycle chain with chain lubricant.

FOR ASSISTANCE WITH  
YOUR ASSEMBLY CALL:  
**1-866-204-9737 TOLL FREE**



# Repair and Maintenance

## Chain and Rear Wheel

**Tools Required:** Phillips Screwdriver, 10 mm Wrench, two (2) 8 mm Wrenches, and two (2) 15 mm Wrenches.

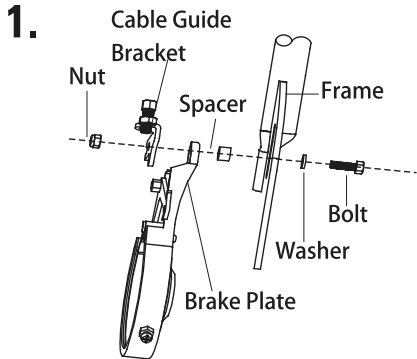

Install the cable guide bracket to the frame and brake plate using bolt, washers, and nut. Do not tighten.

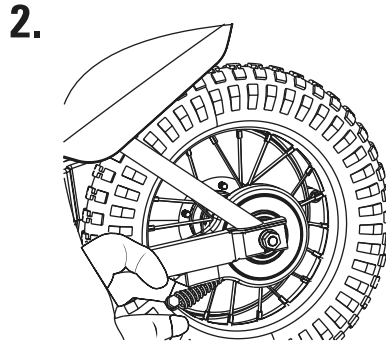

Thread the brake cable through the brake adjuster barrel, through the large spring, and into the small hole in the side of the anchor bolt. Position the cable to the original location (as indicated by the slight cable kink) and tighten securely.

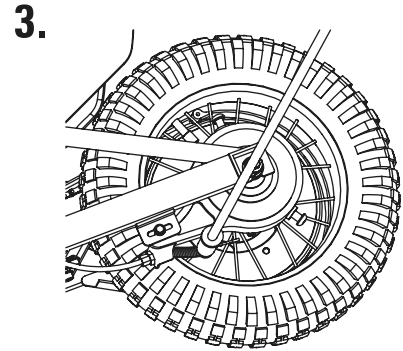

Tighten the cable guide bracket bolt. Tighten the locknuts on the rear axle. Test the brake to verify proper function before riding. Readjust as needed.

### Rear Wheel Parts Diagram

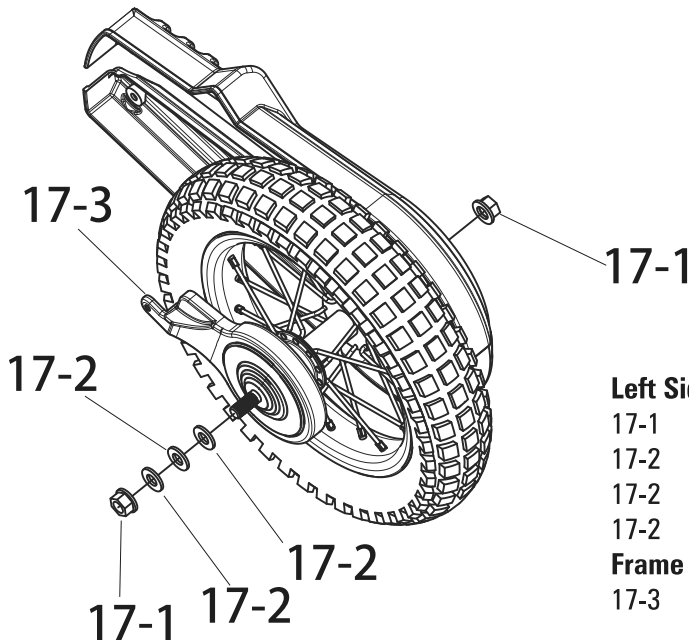

**NOTE:** This is the correct hardware sequence (from outside toward the center).

**Left Side (Brake)**

- 17-1 15 mm Flange Locknut
- 17-2 Flat Washer
- 17-2 Flat Washer
- 17-2 Flat Washer

**Frame**

- 17-3 Brake Plate

**Right Side (Throttle)**

- 17-1 15 mm Flange Locknut

FOR ASSISTANCE WITH YOUR ASSEMBLY CALL:  
**1-866-204-9737 TOLL FREE**

**HYPER TOY CO**

# Repair and Maintenance

## Front Wheel and Fuse Replacement

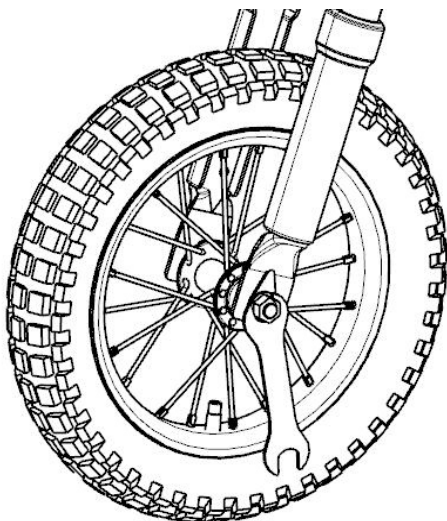

### Front Wheel Replacement

**Tools Required:** 15 mm Wrench

Use 15mm wrench to loosen both axle bolts on the front wheel axle. Remove front wheel from front forks and replace with a HYPER TOY COMPANY front wheel replacement part.

### Fuse Replacement

**Tools Required:** Phillips Screwdriver



**1.** Locate the two engine plate screws and remove with screwdriver.

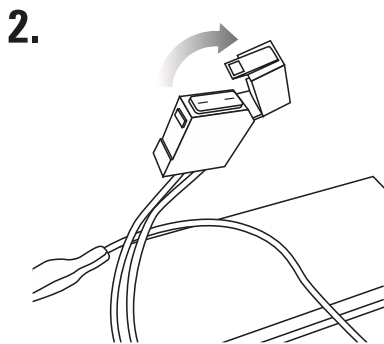

**2.** Locate the fuse box attached to the batteries. Open the fuse cover to expose the fuse.

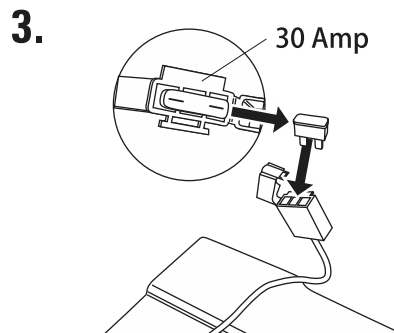

**3.** Remove the fuse and replace with a new one of equal amperage. Close the fuse cover and reattach the battery cover.

FOR ASSISTANCE WITH  
YOUR ASSEMBLY CALL:  
**1-866-204-9737 TOLL FREE**

# Operation

## Electric Motorbike Twist Throttle

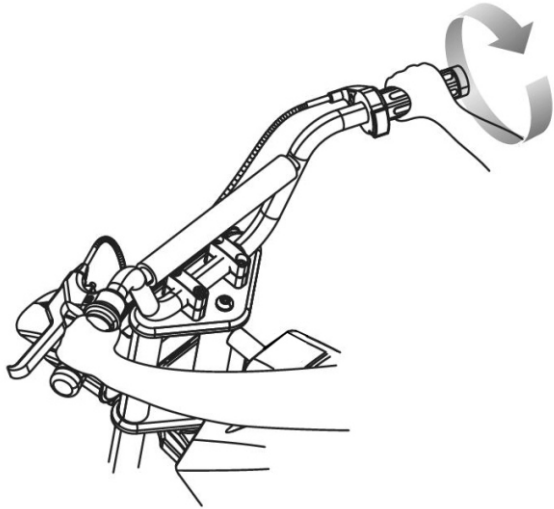

### Accelerate Forward

Place both hands on the handlebars. Slowly push forward with one foot and apply the throttle by twisting right hand back towards you.

**NOTE:** Keep both feet on the foot pegs when unit is in motion.

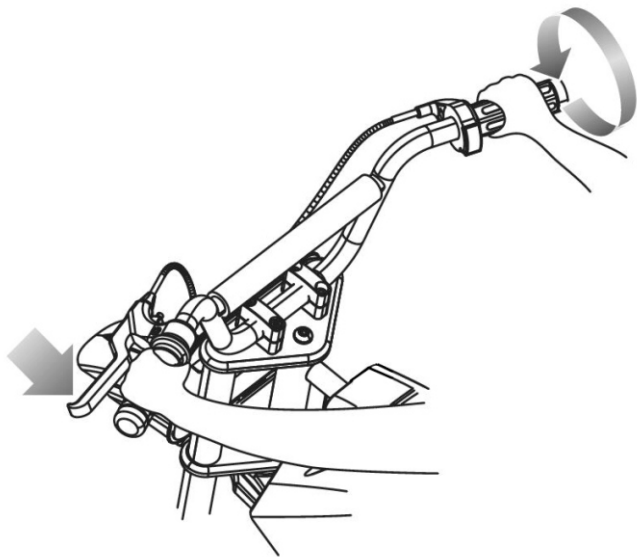

### Slowing Down and Stopping

Release the throttle by twisting right hand forward to throttle start position and apply the brake.

**NOTE:** When coming to a complete stop, place both feet on the ground to balance the unit.

FOR ASSISTANCE WITH  
YOUR ASSEMBLY CALL:  
**1-866-204-9737 TOLL FREE**

# Vehicle Care & Pre-Riding Check

**Vehicle Pre-riding Check:** The following steps need to be followed every time before riding.

Check all screws, cap nuts, chain guards, other covers, and guards regularly. If loose tighten as required. Check plastic parts on a regular basis for cracks or broken pieces.

Before riding test and adjust brakes as shown on pg. 10 of this manual.

Periodically inspect the tires for excess wear and replace as needed. Regularly check the tire pressure and inflate as needed. Regularly check the wheel spoke tension as shown on pg. 9 of this manual.

Check all the safety labels on the vehicle. The rider must understand and follow safety instructions and warnings completely. Failure to follow the safety instruction can cause injury to the rider or damage to this electric motorcycle.

Check for cracks or broken connections. Although a broken frame is rare it is possible. Aggressive riding can lead to frame damage. Always inspect your electric motorcycle before and after riding.

Always wear protective gear, such as ANSI, SNELL, or ASTM approved helmet, knee pads and elbow pads. Always wear shoes and keep shoelaces tied and out of the way of the wheels, motor and drive system.

Always learn and obey any local laws or regulations, which may affect the location where the electric motorbike may be used.. Always stay away from cars and motor vehicle traffic at all times. Only use where allowed with caution and adult supervision.

This electric motorcycle is not equipped with a headlight, do not ride at night or when visibility is limited.

## Vehicle Care

During snow or rainy weather, the vehicle should be stored inside or under a protective cover. Remember to charge the battery at least once per month while your vehicle is not in regular use.

Avoid operating the vehicle in wet or snowy conditions. Do not wash the vehicle with soap and water and never spray vehicle with a water hose. Water or moisture in the motors or electrical switches can cause them to corrode and could cause switch or motor failure.

The vehicle can be wiped down with a soft, dry cloth. For a shiny finish, you can wipe plastic parts with a non-wax furniture polish applied to a soft-cloth. Do not use automotive wax. Do not clean with water.

FOR ASSISTANCE WITH  
YOUR ASSEMBLY CALL:  
**1-866-204-9737 TOLL FREE**

# Troubleshooting

# Solutions Guide

<b>Problem</b>	<b>Possible Cause</b>	<b>Solution</b>
<b>Electric Motorbike Does Not Run</b>	<b>Undercharged Battery</b>	Charge the battery. A new battery should have been charged for at least 12 hours before using the electric motorbike for the first time and up to 12 hours after each subsequent use. Check all connectors. Make sure the charger connector is tightly plugged into the charging port, and that the charger is plugged into the wall. Make sure power flow to the wall outlet is on.
	<b>Loose Wires or Connectors</b>	Check all wires and connectors to make sure they are tight. The fuse will burn out and automatically shut off the power if the motor is overloaded.
<b>Electric Motorbike Was Running But Suddenly Stopped</b>	<b>Motor Protector was Activated</b>	An excessive overload such as a heavy rider or steep hill could overheat the motor and activate the motor protector. Wait at least 1 minute then press the protector reset button next to the charging port on the motorcycle. The motorcycle is ready to use after this.
	<b>Burned-Out Fuse</b>	An excessive overload such as a heavy rider or steep hill could overheat the motor. Replace fuse with a new one of equal amperage. Avoid conditions that caused the fuse to burn out and avoid repeatedly burning out fuse (Refer to page 13 of this manual). Contact Hyper Toy Company at 1-866-204-9737 for diagnosis and repair.
<b>Short Run Time (Less than 15 minutes per charge)</b>	<b>Motor or Electrical Switch Damage</b>	Charge the battery. A new battery should have been charged for at least 12 hours before using the electric motorbike for the first time and up to 12 hours after each subsequent use.
	<b>Undercharged Battery</b>	Check all wires and connectors. Make sure the battery connector is tightly plugged into the charger connector, and that the charger is plugged into the wall.
	<b>Low Tire Air Pressure</b>	The tires are inflated when shipped but they invariably will lose some pressure between the point of manufacturing and your purchase. Refer to instructions on page 9 of this manual to properly inflate tires.
	<b>Old Battery Will Not Except Full Charge</b>	Even with proper care, a rechargeable battery does not last forever. Average battery life is 1 to 2 years depending on product use and conditions. Contact Hyper Toy Company at 1-866-204-9737 for diagnosis and repair.
<b>Electric Motorbike Runs Sluggishly</b>	<b>Brakes Not Adjusted Properly</b>	Refer to brake adjustment instructions on page 10 of this manual.
	<b>Riding Conditions Are Too Stressful</b>	Use only on solid, flat, clean and dry surfaces, such as pavement or level ground.
	<b>Low Tire Air Pressure</b>	The tires are inflated when shipped, but they invariably will lose some pressure between the point of manufacturing and your purchase. Refer to instructions on page 9 of this manual to properly inflate tires.
	<b>Electric Motorbike is Overloaded</b>	Make sure you do not overload the electric motorbike by allowing more than one rider at one time, exceeding the maximum weight limit, going up too steep a hill or towing objects behind the product.
<b>Electric Motobike Sometimes Stays On and Other Times it Doesn't</b>	<b>Loose Wires or Wire Connections</b>	Check all wires around the motor and all connectors to make sure they are tight.
	<b>Electric Motor or Switch Damaged</b>	Contact Hyper Toy Company at 1-866-204-9737 for diagnosis and repair.
<b>Brakes Don't Stop Electric Motobike</b>	<b>Brakes Aren't Adjusted Properly</b>	Refer to instructions on page 10 of this manual to properly adjust brakes.
<b>Loud Noises or Grinding Sounds From Electric Motobike</b>	<b>Chain Needs Lubrication</b>	Apply a lubricant such as 3 in 1™ or Tri-Flow™ to the chain.

FOR ASSISTANCE WITH  
YOUR ASSEMBLY CALL:  
**1-866-204-9737 TOLL FREE**

# Limited Warranty

**DO NOT RETURN YOUR  
VEHICLE TO THE STORE**

1. Product needs to be returned in original packaging and unused and as purchased from your retail store and include the ORIGINAL PURCHASE OR SALES RECEIPT to validate your limited warranty.

2. Products must be New and Unused.

3. Products must be shipped back with Original packing, parts, and accessories.

If any part is found missing when returning each part cost (list on Service Manual) should be deducted from the product purchase amount.

Hyper Toy Company offers the following limitations, terms and conditions to the original owner of the Hyper Toy Company electric ride-on toy. Should this Hyper Toy Company electric ride-on toy or any part be determined defective by Hyper Toy Company to be covered by this limited Warranty, it will be repaired or replaced, at Hyper Toy Company sole option, which will be conclusive and binding. Hyper Toy Company will pay all labor cost, connected with the repair or replacement of all parts covered under this limited warranty. Under no circumstances does this limited warranty include the cost of travel or shipment to and from any retailer or consumer. Such cost, if any, shall be borne by the original or subsequent owner.

This Hyper Toy Company electric ride-on toy has not been designed or engineered for ramp riding, jumping, aggressive riding, riding in severe climates, riding over severe terrain, riding with heavy loads (over 139lbs or 63kgs) or any similar activities. Such uses may damage the Hyper Toy Company electric ride-on toy, that can cause serious injury to the rider and in all cases will void this warranty.

## **6 Months From The Date Of The Purchase On Vehicle**

Hyper Toy Company electric ride-on body, display, throttle and throttle assembly, control wiring harness, wiring and wiring harness, motor and associated transmission and all components not directly associated with the 24V battery are warranted from 6 months from data of purchase to The ORIGINAL PURCHASER against any defects in material, manufacturing, and/or workmanship. If there is any evidence of consumer repair the warranty is voided. Any claim of damage under this clause cannot be due to owner abuse or neglect and must first be reported to Hyper Toy Company Customer Service and a Return Merchandise Authorization (RMA) tag to be issued.

## **3 Months From The Date Of The Purchase On Battery**

The battery must be charged for a full 12 hours but never more than 24 hours before the units first use. The 24V battery and battery charger (AC Adaptor) that is included with the original vehicle is warranted to be free from defects in material, parts and/or workmanship, again not due to owner abuse or neglect. If there is evidence of customer repair or use of other's battery or charger the warranty is voided. This limited warranty is only valid to the original purchaser and must first be reported to Hyper Toy Company Customer Services and a Return Merchandise Authorization (RMA) tag be issued.

Wheels, tires, and brakes are considered a wear and tear item and are only under warranty in the event of manufacturer defect.

Items not covered under warranty terms under any conditions

1. Damage due to failure to maintain the battery as accurately described on various product warning stickers and the products owner's manual.
2. Damage due to maintenance or the actual damage caused by the lack of maintenance.
3. Damage due to improperly assembled products.
4. Damage due to climatic or environmental damage, various cleaners and/or chemicals that may result in damaging the vehicles finish.

This warranty does not cover and is intended to exclude any liability on the part of Hyper Toy Company. Whether under this warranty or implied by law or indirect or consequential damages for breach of warranty.

This warranty gives you specific legal rights. You may also have other rights that vary from state to state and province to province. In those states that do not allow the exclusion of implied warranties or limitation of incidental or consequential damages, the above limitations or exclusions may not apply to you. This warranty applies to the United States and Canada.

**DON'T RETURN YOUR VEHICLE TO THE STORE.** Should you require service or assistance with your vehicle during the warranty period, contact our trained technical staff at Hyper Toy Company 1-866-204-9737.

FOR ASSISTANCE WITH  
YOUR ASSEMBLY CALL:  
**1-866-204-9737 TOLL FREE**



# Product Registration

**HFR350**

**HYPER TOY CO**

## Note:

**Activation of your warranty gives you FREE telephone and online technical service help. Please visit [www.hypertoys.com](http://www.hypertoys.com) to complete product registration and activate your warranty. You will need to provide the product serial number to complete registration. The location of the serial number is on the underside of the vehicle body.**

**Hyper Toy Company  
Customer Service Contact:**  
177 Malaga Park Dr.  
Malaga, NJ 08328

**Call Toll Free  
1-866-204-9737**  
Monday-Friday 8:00AM to 5:00PM (CST)

For product related questions or customer service needs please email [info@hypertoys.com](mailto:info@hypertoys.com)

**VISIT US ONLINE@**  
[www.hypertoys.com](http://www.hypertoys.com)



**WARNING:** USE AT YOUR OWN RISK. ADULT SUPERVISION IS REQUIRED. THIS IS A POWERFUL TOY AND IS NOT INTENDED FOR RIDERS UNDER THE AGE OF 13.

Do not discard this owner's manual. Refer to the manual for important instructions before operating and to progress in skill.

No more than 1 rider at a time. Do not exceed 139lbs (63kgs) rider weight.

Do not allow riders under the age of 13 years old to use this product. Adult supervision is required.

Always wear shoes and proper protective gear, such as ANSI, SNELL, or ASTM approved helmets. Elbow and knee pads are also recommended.

Battery life may be reduced in extreme temperatures or with a maximum weight load.

Use only in safe controlled areas, not on public streets, or near motor vehicles.

Do not ride at night or in low visibility conditions.

Steep, rough, uneven, or wet surfaces can increase risk to the rider.

Be sure to check local regulations to understand how and where it is allowed to use this product.

**CONTAINS SEALED LEAD-ACID BATTERY. MUST BE RECYCLED OR DISPOSED OF SAFELY.**

FOR ASSISTANCE WITH  
YOUR ASSEMBLY CALL:  
**1-866-204-9737 TOLL FREE**