

READ THIS MANUAL BEFORE OPERATING YOUR PHANTOM 4

ELECTRA ACCESSORIES, INC. STRONGLY SUGGESTS THE OPERATOR OF THIS PRODUCT BE 16 YEARS OF AGE OR OLDER.

SCOOT-N-GO™
PHANTOM 4

Assembly and User's Manual

Model#: 88900 / 88901 / 88902 / 88903 / 88904 / 88925



For the most recent version of this user's manual and for all updated product information please visit www.electrausa.com or call Electra Customer Service / Technical Support Toll-Free Number at:

1-888-467-1234

M-F 10am - 9pm EST

Electra Accessories Inc.
2 Corporate Drive
Cranbury, New Jersey 08512 USA
website: www.electrausa.com

ELECTRA™
ACCESSORIES, INC.

YOUR INSURANCE POLICIES MAY NOT PROVIDE COVERAGE FOR ACCIDENTS INVOLVING THE USE OF THE PHANTOM 4™. TO DETERMINE IF COVERAGE IS PROVIDED YOU SHOULD CONTACT YOUR INSURANCE COMPANY OR AGENT.

TABLE OF CONTENTS

Table of Contents.....	2
Features and Specifications.....	3
Contents of the Box.....	3
PHANTOM 4™ General Usage Restrictions and General Safety Instructions.....	3,4,5,6,7
Assembly Instructions.....	8
Battery.....	9,10,11
General Usage Notes.....	11
Drive Chain Maintenance.....	12
Tire Maintenance.....	13
Front Wheel Removal.....	13
Flat Tire Repair.....	13,14,15
Brake Maintenance.....	15
Fuse Replacement.....	16
Key and Throttle Operation.....	17
PHANTOM 4™ Parts.....	18
PHANTOM 4™ Parts.....	19
PHANTOM 4™ Parts.....	20
PHANTOM 4™ Replacements Parts List.....	21
30 Day Warranty & Limitations.....	22
Warranty Service Options & Exclusions.....	23
Return Policy.....	24
Notes.....	25,26

FEATURES & SPECIFICATIONS

FEATURES AND SPECIFICATIONS

- Motor Specs: Permanent Magnet Brush DC Motor, Rotated Power: 180W, Speed: 290r/min
- Recharge Time for the Battery: 4-6 Hours
- Battery Holds 4-6 Hours of ride Time
- One Full Charge Lasts up to 37 miles
- Speeds up to 19 mph on level pavement with 170 lb rider
- Weight of PHANTOM 4™: 108 lbs

CONTENTS OF THE BOX

- PHANTOM 4™ with 36v battery installed (charging required)
- Left and right pedals (assembly required with tool kit included)
- PHANTOM 4™ 36v charger for 110v AC outlet
- Tool Kit which contains: 1 pc. 5mm Allen key wrench and 1 pc. 8/10 mm open ended wrench
- Assembly and User's manual that includes a replacement parts list (for ordering additional or repair parts)
- Two Ignition Keys (also used for under seat storage and main battery compartment)
- Two Storage Box Keys
- Spare fuses (20 amp, in the User's Manual Bag)

GENERAL USAGE RESTRICTIONS AND GENERAL SAFETY INSTRUCTIONS

This Manual contains many **⚠ WARNING** notes concerning the consequences of failure to maintain or inspect your PHANTOM 4™. A **⚠ WARNING** means that failure to follow the instructions following it may result in injury to the rider or others during use, which may include losing control and falling. Because any fall can result in serious injury or even death, we do not repeat the warning of possible injury or death whenever the risk of falling is mentioned. A **⚠ CAUTION** on the other hand means that failure to follow the instructions following it may result in damage to the PHANTOM 4™ or component during installation or use. (I.e. risk of property (product) damage only)

Thank you for purchasing the low speed electrically powered "PHANTOM 4™".
The PHANTOM 4™ complies with U.S. Consumer Product Safety Commission (CPSC) regulation 16 CFR part 1512.

GENERAL SAFETY GUIDELINES & RESTRICTIONS

Your state department of motor vehicles (DMV), or the city or county where it will be used, may regulate the use of devices like the PHANTOM 4™. Some states may require a driver's license or minimum age to use the PHANTOM 4™, require the PHANTOM 4™ to be registered or licensed or require some additional type of equipment like a brighter headlight. In some states it may be referred to as an "electric bicycle" or "electric scooter". Please check with your state DMV or local municipality on requirements for using the PHANTOM 4™. They can be located in the phonebook. State DMV offices can also be located on the Internet at such sites as the following www.dmv.org or www.statehousegirls.net/agencies/dmv.

If your state or municipality allows the PHANTOM 4™ to be used on vehicle roadways please make sure you are familiar with all traffic laws as set forth by your state DMV, such as yielding to pedestrians and other motorists, signaling, riding as far to the right edge of the roadway as possible, obeying traffic signs etc. Your state DMV can provide you with materials setting forth these traffic laws.

In addition to those traffic laws abide by the following general principals:

1. You are sharing the road or the path with others -- motorists, pedestrians and other cyclists. Respect their rights, and be tolerant if they infringe on yours.
2. Ride defensively.
3. Look ahead of where you're going, and be ready to avoid:
 - Vehicles slowing or turning in front of you, entering the road or your lane ahead of you, or coming up behind you.
 - Parked car doors opening in front of you.
 - Pedestrians stepping out in front of you.
 - Children or dogs playing near the road.
 - Pot holes, sewer grating, railroad tracks, expansion joints, road or sidewalk construction, debris and other obstructions that could cause you to swerve into traffic, catch your wheel or otherwise cause you to lose control and have an accident.
 - The many other hazards and distractions which can occur while using the PHANTOM 4™ during a ride.
4. Ride on the right side of the road, in the same direction as vehicle traffic and as close to the edge of the road as possible.
5. Stop at stop signs and traffic lights; slow down and look both ways at street intersections. Remember that the PHANTOM 4™ will always lose in a collision with a motor vehicle, so be prepared to yield even if you have the right of way.
6. Use hand signals for turning and stopping. Learn the local vehicle code for the correct signal.

GENERAL SAFETY GUIDELINES & RESTRICTIONS

8. Don't weave through traffic or make any moves that may surprise people with whom you are sharing the road.
9. Never carry anything which obstructs your vision or your complete control of the PHANTOM 4™, or which could become entangled in the moving parts of the PHANTOM 4™.
10. Never hitch a ride by holding on to another vehicle.

NEITHER ELECTRA ACCESSORIES NOR THE RETAIL SELLER OF THE PHANTOM 4™ IS RESPONSIBLE FOR THE CONSEQUENCES OF FAILURE TO COMPLY WITH STATE AND LOCAL ORDINANCES RELATING TO THE USE OF THE PHANTOM 4™

⚠ WARNING California Proposition 65:

This product contains lead and lead compounds, chemicals known to the State of California to cause cancer and reproductive harm. Wash hands after handling.

HELMET USE WHILE RIDING THE PHANTOM 4™

Your state DMV, or the city or county where it will be used, may require that you use a helmet that meets the federal Department of Transportation "DOT" requirements (like those used by motorcycle riders) while riding the PHANTOM 4™. Other states or municipalities may require that a helmet meet the Consumer Product Safety Commission (CPSC) helmet requirements (like those used by human powered bike riders) while riding the PHANTOM 4™. Even if your State or municipality has no requirements concerning helmet use, the PHANTOM 4™ should not be used under any circumstances without properly wearing a helmet that either meets the DOT or CPSC regulations. The helmet must have a label inside which indicates which regulation it meets. If you are unsure contact DOT at www.nhtsa.gov (888-327-4236) or CPSC at www.cpsc.gov (800-638-2772).

⚠ WARNING

IN ADDITION TO THE REQUIREMENTS ABOVE, THE PHANTOM 4™ IS NOT TO BE RIDDEN / USED:

1. on any roadways where the speed limit is in excess of 30 mph
2. on any sidewalks or pedestrian walkways
3. on any bumpy, rough or unpaved surfaces
4. in darkness
5. on sandy, wet or gravel covered surfaces
6. by any person weighing more than 225 lbs
7. by any person shorter than 60"
8. by any person with an inseam of less than 22"

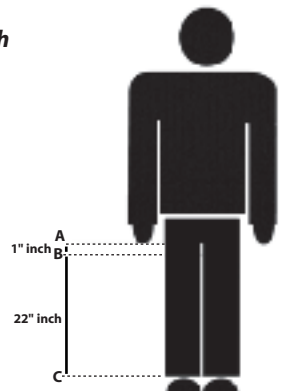

GENERAL SAFETY GUIDELINES & RESTRICTIONS

9. *by more than one rider at a time (no passengers)*
10. *by any physically or mentally challenged person*
11. *by any person with vision, balance, hearing or coordination impairments*
12. *by any person using headphones or a cellular phone [They mask traffic sounds and emergency vehicle sirens, distract you from concentrating on what's going on around you, and their wires can tangle in the moving parts of the PHANTOM 4™, causing you to lose control]*
13. *to carry more than 10 lbs of cargo in the cargo compartment (in addition to the rider)*
14. *in excess of 20 mph (with or without the motor activated)*
15. *by barefoot riders or those wearing sandals, open toed, high heeled, platform or slip on footwear*
16. *on steep inclines or on uneven terrain*
17. *by any person who has ingested any alcohol or drug that could impair their ability to operate the PHANTOM 4™*
18. *without 2 hands on the handle bar*
19. *while not seated on the seat*
20. *to jump ramps, curbs, or objects or attempt any stunts*
21. *with excessive speed for the terrain, circumstances or maneuver with clothing or extremities in close proximity to the drive chain or any moving parts*
22. *beyond your ability or prior experience*
23. *by stopping with only the front brake. Use both brakes simultaneously*
24. *Do not try to accelerate and have the brake (s) on at the same time.
[This may cause damage to the motor or drive train or cause the motor or drive train to overheat.]*

⚠ WARNING BEFORE EACH RIDE: **⚠ CAUTION**

1. *Make sure you properly (per the instructions in the helmet) wear a helmet that meets DOT or CPSC regulations*
2. *Wear protective clothing and gloves*
3. *Wear eye protection that does not interfere with your peripheral vision*
4. *Check local and state laws before operating the PHANTOM 4™ in any area*
5. *Make sure all tail/brake lights, turn signals and headlight are operational*
6. *Make sure the horn is operational*
7. *Make sure the brakes are properly adjusted and working correctly (see page #15).*
8. *Make sure you understand how the brakes work (right lever for rear brake) and that your hands can reach and squeeze the levers comfortably and hard enough to stop the PHANTOM 4™ safely.*
9. *Make sure the chain is properly adjusted (see page #12).*

GENERAL SAFETY GUIDELINES & RESTRICTIONS

10. *Make sure all parts of the PHANTOM 4™ are properly and securely fastened and adjusted, including but not limited to pedals, crank arms, wheels, all controls and cargo (Please refer to Assembly Instructions)*
11. *Make sure the tires are not excessively worn, do not have tears or cuts, and are properly seated on the rim and inflated to the proper pressure on the sidewall (DO NOT USE GAS STATION PUMPS FOR INFLATION)*
12. *Make sure the wheels spin straight and that the rims are not bent or damaged (front wheel must be undamaged for front brake to work properly)*
13. *Make sure the throttle is in the "OFF" position before turning PHANTOM 4™ key on. This will prevent the PHANTOM 4™ from moving forward without notice once the ignition key is turned.*

⚠ WARNING AFTER EACH RIDE: **⚠ CAUTION**

1. *Make sure that the ignition key is turned off and that all keys are removed and kept in a safe place*
2. *Make sure that the battery is not left fully discharged or close to fully discharged*
3. *Make sure the throttle is rotated to the off position*
4. *Ensure that the kickstand is used so the PHANTOM 4™ will not fall over and get damaged*
5. *Ensure the PHANTOM 4™ is not kept outdoors or where moisture can damage it*
6. *Do not charge or store the PHANTOM 4™ closer than 20 feet from any flame (e.g. furnace, fireplace, water heater, space heater)*
7. *Do not allow children under 16 to play on or near the unattended PHANTOM 4™*

⚠ WARNING FAILURE TO FOLLOW THESE OPERATION INSTRUCTIONS CAN RESULT IN SERIOUS INJURY OR DEATH OR COULD RESULT IN AN ELECTRICAL SHORT AND OR FIRE.

⚠ WARNING DO NOT MAKE ANY ALTERATIONS OR MODIFICATIONS TO THE PHANTOM 4™, OR ADD ANY PARTS NOT AUTHORIZED BY ELECTRA EXCEPT THOSE DISCUSSED IN THIS MANUAL OR THOSE REQUIRED BY LAW. DO NOT REMOVE ANY REFLECTORS, LIGHTS OR OTHER STANDARD EQUIPMENT.

All authorized replacement parts are listed on the parts list enclosed with the PHANTOM 4™ or available at www.electraUSA.com or by calling Electra customer service at 1-888-467-1234 M-F 10am - 9pm EST.

ASSEMBLY INSTRUCTIONS

After unpacking your PHANTOM 4™ there is minimal assembly to be completed. Assembly consists of attaching the pedals to the PHANTOM 4™ and attaching the rearview mirrors.

PEDALS

Locate Pedals (Set of 2) The pedals are labeled left and right near the threads. They are not interchangeable. The left pedal goes into the threaded hole on the left crank arm on the left side of the PHANTOM 4™ (your left side as if seated on the PHANTOM 4™). The inside surface of the crank arms are labeled "L" and "R" like the pedals. The Left pedal has reverse threading meaning it tightens by turning it to the left (counter-clockwise). The Right pedal has normal threading and tightens by turning it to the right (clockwise). After threading the pedals into the crank arms as far as possible with your fingers (to avoid cross threading), tighten them snugly with an adjustable wrench.



REARVIEW MIRRORS (SOLD SEPERATELY)



Locate the chrome mirrors included with your PHANTOM 4™. These have threaded ends and include a nut. With the Hexagonal ("Allen" or "Hex" wrench) Key provided in your PHANTOM 4™ toolkit, remove the screw and nut as shown in the pictures. Once the nut is removed from the threaded end of each mirror, insert the threaded end of the mirror as shown on picture at left. Then screw the nut onto the mirror's threaded end as shown on picture below.

The mirror needs to be tightened fully for assembly to be safe. Repeat the process for the other mirror. Once mirrors are installed, they should look like the picture on left. Make sure to adjust the mirrors before use so that you can see behind you as you ride.

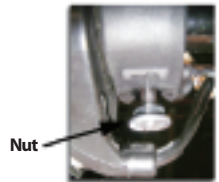

You have now successfully assembled your PHANTOM 4™!
If you have any questions about assembly please call :
Electra Customer Service / Technical Support
Toll-Free at 1-888-467-1234 M-F 10-am - 9pm EST.



BATTERY

BEFORE OPERATING YOUR NEW PHANTOM 4™, FOR THE FIRST TIME, CHARGE THE BATTERY FOR 14-16 HOURS, BUT UNDER NO CIRCUMSTANCES IN EXCESS OF 18 HOURS.

Be sure to charge the PHANTOM 4™ after each use. Keeping the battery properly charged will help extend the battery life. Do not use the PHANTOM 4™ while the power indicator on the instrument panel shows low energy. If the PHANTOM 4™ is over-used the battery's life will be reduced. The PHANTOM 4™ uses a 36V (volt) battery pack. To charge the battery, connect the 3-pin plug into the charging receptacle located directly below the front of seat. The battery must be charged while installed in the PHANTOM 4™. If you notice anything unusual about the battery such as a cracked or leaking battery case, a battery that gets hot while being used or charged, a battery case that appears "puffy" or "bloated" etc, or there are any other problems with the battery, please contact Electra Customer Service / Technical Support Toll-Free at: 1-888-467-1234 M-F 10am - 9pm EST.

The battery is sealed and is NOT user serviceable. Do not attempt to repair, remove, adjust or in any way alter any internal or electrical components, controls or wiring without first speaking with a customer service representative.

The main battery weighs approximately twenty eight (28) pounds. There is no need to remove it from the PHANTOM 4™ unless you are replacing it. Use caution on removal. To replace the main battery pack, lift the foot mat and unlock the lock located on the left side of the PHANTOM 4™ (using the ignition key). Proceed to pull the battery out utilizing the handle. Disconnect the battery cable. **The PHANTOM 4™ is equipped with a 36V battery charger that will interrupt the charging process once the battery has received a sufficient charge. Electra Accessories, Inc. strongly suggests that the charger not be used in excess of 18 hours to prevent any unnecessary wear on the battery or charger itself. Charging for periods greater than 18 hours may reduce the overall life expectancy and efficiency of these items.**



BATTERY

*******DO NOT DROP THE PHANTOM 4™ BATTERY*******

CHARGING THE PHANTOM 4™ BATTERY

⚠ CAUTION

TO AVOID DAMAGE TO THE BATTERY WHEN CHARGING, USE ONLY THE CHARGER PROVIDED WITH YOUR PHANTOM 4™.

- ⚠ WARNING** **DO NOT CHARGE OR STORE THE PHANTOM 4™ CLOSER THAN 20 FEET FROM ANY FLAME (E.G. FURNACE, FIREPLACE, WATER HEATER, SPACE HEATER)**
- Be sure to only use 110V AC with the PHANTOM 4™ charger. Also make sure the plug is inserted into a three prong grounded AC outlet.
- PLUG the POWER INPUT CORD into the PHANTOM 4™ charging receptacle located below the front of the seat. See picture above.
- Plug the PHANTOM 4™ 36V battery charger into a 110V AC power source.
- The CHARGER INDICATOR LIGHT will illuminate confirming that power is connected to the charger. If the light does not come on check all connections. If it still does not come on after checking all connections, fuses and that your AC plug is working, unplug the charger and call Electra Customer Service / Technical Support Toll-Free at 1-888-467-1234 M-F 10am - 9pm EST

BATTERY

6. **⚠ WARNING** *DO NOT KEEP THE PHANTOM 4™ CONNECTED TO THE CHARGER FOR LONGER THAN 18 HOURS UNDER ANY CIRCUMSTANCES! DOING SO COULD CAUSE THE BATTERY OR CHARGER TO OVERHEAT AND CAUSE A FIRE.*
7. When the light on the 36V charger is blinking, the PHANTOM 4™ battery is being properly charged. When the PHANTOM 4™ battery is fully charged, the light will remain lit without blinking (see 36V charger for example). If this does not occur after approximately 16 hours of charging, unplug the charger and call Electra Customer Service/Technical Support. Normal recharge time for the main battery is 4-6 hours (assuming it is not 100% discharged).
8. Disconnect the Input Cord from the Charging Receptacle.
9. Disconnect the charger from the 110V Power Source.
10. **⚠ WARNING** *NEVER LEAVE THE BATTERY CHARGER CONNECTED TO THE 110V POWER SOURCE OR THE PHANTOM 4™ WHEN NOT CHARGING THE BATTERY. KEEPING THE CHARGER PLUGGED INTO THE 110V POWER SOURCE AND NOT THE BATTERY COULD CAUSE THE CHARGER TO OVERHEAT AND OR CAUSE A FIRE.*
11. When storing your PHANTOM 4™ for lengthy periods of time, the battery should be charged at least once a month to avoid full depletion.

⚠ WARNING *FAILURE TO KEEP THE PHANTOM 4™ BATTERY CHARGED WILL CAUSE TOTAL BATTERY FAILURE. DO NOT ALLOW BATTERY TO BECOME FULLY DISCHARGED!!! ALWAYS RECHARGE THE BATTERY BEFORE THE POWER INDICATOR ON THE INSTRUMENT PANEL SHOWS NO POWER. ALLOWING THE BATTERY TO FULLY DISCHARGE WILL REDUCE BATTERY LIFE AND MAY RUIN THE BATTERY OR COULD CAUSE THE BATTERY OR CHARGER TO OVERHEAT AND CAUSE A FIRE THE NEXT TIME THE PHANTOM 4™ IS CHARGED.*

⚠ WARNING *California Proposition 65: BATTERY POSTS, TERMINALS, POWER CORDS AND BRAKE CABLES MAY CONTAIN LEAD AND LEAD COMPOUNDS, CHEMICALS KNOWN TO THE STATE OF CALIFORNIA TO CAUSE CANCER AND REPRODUCTIVE HARM. WASH HANDS AFTER HANDLING.*

BATTERY



BATTERY RECYCLING



When maintained and used properly, (by following charging and storage guidelines), the Lead Acid Battery Pack used in this product has a normal lifespan of many miles. When the battery pack no longer holds a charge or is unable to be charged properly, it should be removed from the PHANTOM 4™ and delivered to a recycling facility. State Laws prohibit disposal of lead-acid batteries in everyday trash. Please contact your local solid waste or recycling authority for recycling information in your area.

GENERAL USAGE NOTES

Break-in Period: Your PHANTOM 4™ will last longer and work better when it is broken in properly. Brake control cables and chains may stretch or "seat" when a new PHANTOM 4™ is first used and may require an adjustment. We suggest that the brakes and chain be checked every 30 days and adjusted if necessary.

The PHANTOM 4™ is not intended to be used without the installation of the pedals. Pedaling the PHANTOM 4™ upon starting will save battery life and will make it easier to balance the PHANTOM 4™. The PHANTOM 4™ can also be pedaled in situation where the battery power is too low due to a failure to charge the PHANTOM 4™ or exceeding its distance range. The rider can also rest his or her feet on the pedals while riding the PHANTOM 4™ under electrical power.

It is a good idea to keep the PHANTOM 4™ tool kit with you when you ride. You should also carry 2 spare inner tubes that fit the wheel and tire size (available from Electra at www.electraUSA.com) as well as a manual air pump (with gauge) to re-inflate the tire if you have a flat or it becomes low during use. A handy air pump we suggest looking at is available at www.minifootpump.com

If your PHANTOM 4™ sustains an impact:

⚠ WARNING ***A CRASH OR OTHER IMPACT CAN PUT EXTRAORDINARY STRESS ON COMPONENTS, CAUSING THEM TO FATIGUE PREMATURELY. COMPONENTS SUFFERING FROM STRESS FATIGUE CAN FAIL SUDDENLY AND CATASTROPHICALLY, CAUSING LOSS OF CONTROL, SERIOUS INJURY OR DEATH.***

First, check yourself for injuries, and take care of them as best you can. Seek medical help if necessary. Next, if your PHANTOM 4™ is damaged, perform the checks described in this manual. If you are unable to fix any or all damage/problems, or if you find any bent, scored, or discolored parts, please call Electra Customer Service at 1-888-467-1234 M-F 10am - 9pm EST or visit the Electra website at electraUSA.com for replacement parts.

⚠ WARNING ***IF YOU HAVE ANY DOUBT ABOUT THE CONDITION OF THE PHANTOM 4™ OR ANY OF ITS PARTS, CALL ELECTRA CUSTOMER SERVICE AT 1-888-467-1234 M-F 10AM - 9PM EST AND THEY WILL ASSIST YOU IN PERFORMING A THOROUGH CHECK.***

MAINTENANCE

Technological breakthroughs have made components more complex than ever before, and the pace of innovation is increasing. This on-going revolution makes it impossible for this manual to provide all the information required to properly repair and/or maintain your PHANTOM 4™. In order to help minimize the chances of an accident and possible injury, it is critical that you have all repair and maintenance work performed regularly.

For more detailed maintenance instructions or for ordering replacement parts please contact Electra Customer Service / Technical Support Toll-Free at 1-888-467-1234 M-F 10am - 9pm EST. Local bicycle retail stores, which have service facilities in your area, can also assist you with certain non-electrical repairs or adjustments that you are not qualified to make or for which you do not have the specific or specialized tools needed for repair.

DRIVE CHAIN MAINTENANCE

Periodic adjustments of the drive chain will be necessary to maintain proper tension. If the drive chain is loose, it may make a "popping" noise, which indicates a need for immediate adjustment. To manually check the drive chain tension, make sure the drive chain is properly seated on both the front and rear sprockets. Move the top portion of the drive chain in an upward direction, approximately 1". If there is greater than approximately 1" of movement, the drive chain must be adjusted before use to



avoid unseating "falling-off". Before adjusting the chain, please make sure the key is in the "position and disconnect the battery power to prevent any injuries or damage. To disconnect the main battery power, lift the foot mat and unlock the lock located on the left side of the PHANTOM 4™ (using the ignition key). Proceed to pull the battery out utilizing the handle. Disconnect the battery cable. Loosen both rear axle nuts until the wheel will move freely in the axle slots forward and backwards. The drive chain tension is changed by adjusting the tension adjustment screws



behind the rear axle until the proper tension is achieved. The screws must be turned clockwise to tighten, and counter-clockwise to loosen the chain. Check the tension by rotating the wheel by hand. Be sure that the drive chain is not too tight, if so, the chain will break. Tighten the rear axle nuts and re-check the tension. Make sure that the rear wheel is installed straight and that the tension adjustment screws have not caused the rear wheel to sit crooked once the axle nuts are tightened. The chain should be cleaned and lubricated with bicycle chain lubricant (available at local bike shops) after every 100 miles of riding (or every three rides) or after riding the PHANTOM 4™ in wet road conditions.

TIRE MAINTENANCE

Make sure that the air pressure for all tires is correct. The proper inflation amount is listed on the sidewall of the tire. If the tires have less than the recommended amount of pressure, this will decrease the battery usage time and may cause the unit to handle poorly or cause damage to the tires. Use an air pressure gauge to check for the air pressure of the tire.

⚠ WARNING *DO NOT USE GAS STATION AIR FILLING STATIONS AS THE PRESSURE IS USUALLY TOO HIGH AND THE GAUGES ARE INACCURATE. OVER INFLATION OF THE TIRE COULD CAUSE A BLOW OUT AND CRASH.*

FRONT WHEEL REMOVAL

The PHANTOM 4™ front forks utilize a secondary wheel retention device to keep the wheel from disengaging if the axle nut is insufficiently tightened. Secondary retention devices are not a substitute for correct axle nut tightening. Call Customer Service at 1-888-967-1234 M-F 10am-9pm EST to explain the particular secondary retention device on your PHANTOM 4™ or if you do not understand how to properly remove and replace the front wheel properly with the secondary retention device.

⚠ WARNING *Permanent removal or disabling of retention device is extremely dangerous and may lead to serious injury or death. It also will void the warranty.*

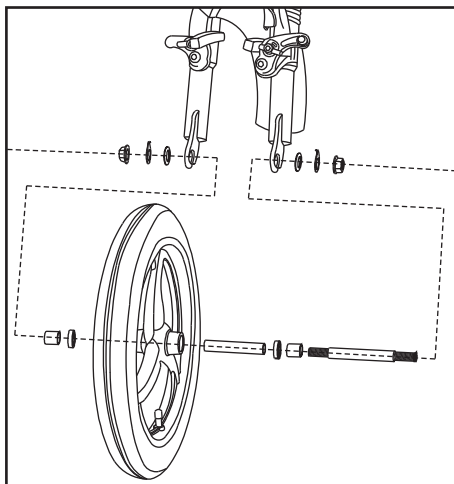

FLAT TIRE REPAIR

To change a tire or inner tube, it is a good idea to keep the PHANTOM 4™ tool kit with you when you ride. You should also carry plastic "tire levers" (available at local bike shops), 2 spare inner tubes that fit the wheel and tire size 16" x 2.125" (available from Electra at www.electraUSA.com or by calling Customer Service at 1-888-967-1234 M-F 9am-4pm PST) as well as a manual hand pump to re-inflate the tire if you have a flat or it becomes low during use.

FLAT TIRE REPAIR (continued)

1. Depress the tire valve to let all the air out of the tube, which will assist in removing the wheel from the PHANTOM 4™.
2. Remove the wheel from the PHANTOM 4™ using a wrench. Loosen the nuts counterclockwise and make sure to remove the wheel retention clips on the front wheel. Be sure to remember where all the spacers and washers belong. For rear tire removal you will also need to slip the chain off the rear sprocket to remove the wheel. The chain must be properly reinstalled and re-tensioned when reinstalling the rear wheel. Make certain the chain is properly positioned on both front and rear sprockets before re-tightening rear wheel.
3. Remove one bead of the tire from the rim by grasping it at a point opposite the valve stem with both hands and, at the same time, lifting and peeling one side of the tire off the rim. If the bead is on too tight for you to unseat it with your hands use tire levers to lift the bead carefully over the tire rim. Tire levers can be purchased at any local bike shop. Push the valve stem through the wheel rim. Remove the inner tube.
4. Carefully check the outside and inside of the tire for the cause of the puncture and remove any debris or damaging material from the inside or outside of the tire.

⚠ WARNING *IF THE TIRE IS CUT, YOU MUST REPLACE THE TIRE TO PREVENT ANY SUDDEN AND CATASTROPHIC FAILURE CAUSING LOSS OF CONTROL, SERIOUS INJURY OR DEATH.* Replacement parts are able to be purchased by calling the Electra Customer Service at 1-888-967-1234 M-F 10am - 9pm EST or by visiting Electra's web site at www.electraUSA.com.

⚠ WARNING *PATCHING A TUBE IS AN EMERGENCY REPAIR. CARELESS PATCHING OR APPLYING SEVERAL PATCHES CAN SERIOUSLY WEAKEN THE TUBE, RESULTING IN POSSIBLE TUBE FAILURE, WHICH COULD CAUSE YOU TO LOOSE CONTROL AND FALL. REPLACE A PATCHED TUBE AS SOON AS POSSIBLE.*

5. Reinstall the tire and tube. Slip one tire bead over the rim. Inset the tube valve through its hold in the rim. Feed the tube carefully into the cavity of the tire. Inflate the tube just enough to give it some shape. Starting at the valve stem and working around both sides of the rim to the side opposite the valve stem, use your thumbs to push and seat the other bead of the tire inside the rim. Be careful not to pinch the tube between the tire bead and the wheel rim. If you have trouble getting the last few inches of bead over the edge of the rim with thumb pressure, use a tire lever and be careful not to pinch the tube.

⚠ CAUTION *IF YOU USE A SCREWDRIVER OR ANY TOOL OTHER THAN A TIRE LEVER, YOU ARE LIKELY TO PUNCTURE THE TUBE.*

6. Check to make sure that the tire is evenly seated around both sides of the rim and that the tube is inside the tire beads. Push the valve stem into the tire to make sure that its base is seated within the tire's beads. Inflate the tube slowly to the recommended pressure on the tire sidewall, all the while checking to make sure that the tire beads stay seated in the rim. Replace the valve cap. Replace the wheel in the PHANTOM 4™.

⚠️ WARNING *RIDING YOUR PHANTOM 4™ WITH A FLAT OR UNDER-INFLATED TIRE CAN SERIOUSLY DAMAGE THE TIRE, RIM (WHEEL), TUBE, AND THE PHANTOM 4™. IT MAY ALSO CAUSE YOU TO LOSE CONTROL AND FALL.*

Make sure that the air pressure for all tires is correct. The proper inflation amount is listed on the sidewall of the tire. If the tires have less than the recommended amount of pressure, this will decrease the battery usage time and may cause the unit to handle poorly or cause damage to the tires. Use an air pressure gauge to check for the air pressure of the tire.

⚠️ WARNING *DO NOT USE GAS STATION AIR FILLING STATIONS AS THE PRESSURE IS USUALLY TOO HIGH AND THE GAUGES ARE INACCURATE. OVER INFLATION OF THE TIRE COULD CAUSE A BLOW OUT AND CRASH.*

BRAKE MAINTENANCE

Take a look at the brake pads before every ride. If when the brake lever is engaged (approximately one (1) inch of brake lever movement) and the brake pads are not firmly against the wheel rim, do NOT ride the PHANTOM 4™. Call Electra Customer Service at 1-888-967-1234 M-F 10am - 9pm EST or visit your local bicycle dealership and have them adjusted or replaced.

Check the control cables and cable housings. Any rust? Kinks? Fraying? If so, do NOT ride the PHANTOM 4™. Call Electra Customer Service at 1-888-467-1234 M-F 10am - 9pm EST or visit your local bicycle dealership and have them adjusted or replaced.

Adjusting the brake cables at the brake lever can be accomplished by most people, however brake pad adjustment or cable replacement should only be performed by people with expertise in performing such adjustments or repairs. Call the Electra Customer Service / Technical Support Toll-Free Number at: 1-888-467-1234 M-F 10am - 9pm EST for additional information about brake repairs or adjustments.

MAIN BATTERY FUSE REPLACEMENT

The PHANTOM 4™ has one 20 Amp fuse located on the main battery pack. Replacement fuses are supplied in the user's manual bag. To replace the fuse from the main battery pack, lift the foot mat. Unlock the lock located on the left side of the PHANTOM 4™ (using the longer in length ignition key). Proceed to pull the battery out utilizing the handle. Disconnect the battery cable. Once the battery has been pulled out of the compartment, locate the fuse holder located next to the plug on the bottom of battery. Replace this fuse with same type and amperage. Using the wrong fuse will result in damage to the PHANTOM 4™. Replacement fuses are supplied in the user's manual bag.

Contact Electra Customer Service / Technical Support Toll-Free at 1-888-467-1234 M-F 10am - 9pm EST or visit the Electra web site at www.electraUSA.com to purchase additional spare fuses.



(OPTIONAL) SPARE BATTERY FUSE REPLACEMENT

The spare battery pack is optional and is not shipped with the PHANTOM 4™. One can be purchased from Electra Customer Service / Technical Support Toll-Free at 1-888-467-1234 M-F 10am - 9pm EST or by visiting the Electra web site at www.electraUSA.com. The spare battery is used to extend the riding range of the PHANTOM 4™.



The spare battery is located in the under-seat storage compartment. This compartment can be used for storage if no spare battery is being used. To access this spare battery, locate the seat lock on the left side of the PHANTOM 4™. Raise the seat to expose the spare battery. Remove the power cable from the socket on the battery. Using the handle, lift the battery out of the battery compartment. It weighs approximately twenty eight (28) pounds so be careful not to drop it (use caution). The fuse holder is located next to the power socket on battery. Replace this fuse with the same type and amperage.

⚠ WARNING USING THE WRONG FUSE WILL RESULT IN DAMAGE TO THE PHANTOM 4™. MAKE SURE THE REPLACEMENT FUSE IS A STANDARD 20 AMP FUSE THAT PROPERLY FITS INTO THE FUSE HOLDER. IF YOU USE THE WRONG SIZE OR AMPERAGE FUSE IT COULD RESULT IN A FIRE OR DAMAGE TO THE PHANTOM 4™.

OPERATING INSTRUCTIONS

KEY AND THROTTLE OPERATION



ON/OFF Switch: (ignition)

1. OFF Position: PHANTOM 4™ is OFF
2. "center" ON Position: PHANTOM 4™ is ON, utilizes the primary battery.
3. ON Position: PHANTOM 4™ is ON, utilizes power from the optional spare battery under the seat.

⚠ CAUTION

BEFORE OPERATING YOUR PHANTOM 4™ MAKE SURE THAT THE THROTTLE GRIP IS NOT ROTATED TO THE "ON" POSITION!!!

SEE PICTURE FOR CORRECT PLACEMENT OF LEVER BEFORE USAGE!!!

THROTTLE CONTROL

The PHANTOM 4™ uses a speed changing throttle grip. It is on the right side of the handlebar. Rotate the throttle grip toward the seat to accelerate and rotate forward away from the seat to slow down.

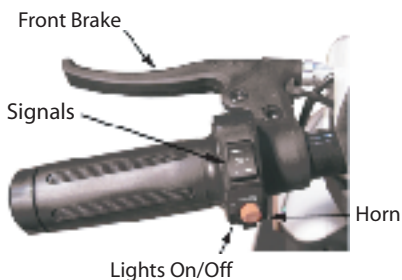

PARTS

PHANTOM 4™ PARTS - 88900 / 88901 / 88902 / 88903 / 88904 / 88925



PARTS

PHANTOM 4™ PARTS - 88900 / 88901 / 88902 / 88903 / 88904 / 88925



PARTS DIAGRAM

PHANTOM 4™ PARTS - 88900 / 88901 / 88902 / 88903 / 88904 / 88925



PARTS LIST

No.	Description	Part No.	Cost
1	36 Volt Battery Charger	33001	\$19.95
2	36 Volt Lead Acid Battery Pack	33002	\$99.95
3	36 Volt Lead Acid Battery (Spare)	33003	\$79.95
4	Axle (Front Wheel)	33004	\$5.95
5	Axle (Inner Axle Spacer)	33005	\$1.95
6	Battery Charging Port (Female Connector Plug)	33006	\$2.95
7	Brake Assembly (Front)	33007	\$19.95
8	Brake Assembly (Rear)	33008	\$29.95
9	Brake Cable w/ Lever (Front)	33009	\$12.95
10	Brake Cable w/ Lever (Rear)	33010	\$14.95
11	Brake Pads Front (Set of 2)	33011	\$8.95
12	Bulbs - Headlight & Instrument Cluster CLEAR (Set of 2)	33012	\$5.95
13	Bulbs - Headlight LARGE CLEAR (Set of 2)	33013	\$3.95
14	Bulbs - Steering Headlight & Instrument Cluster AMBER (Set of 2)	33014	\$5.95
15	Bulbs - Steering Headlight CLEAR (Set of 2)	33015	\$5.95
16	Bulbs - Tail Light - CLEAR - (Set of 2)	33016	\$5.95
17	Bulbs - Tail Light - RED	33017	\$5.95
18	Carpeted Foot Mat	33018	\$12.95
19	Chain (Drive)	33019	\$10.95
20	Control Module	33020	\$19.95
21	Fork Bearing Race (Front) (Set of 2)	33021	\$5.95
22	Fork Bearings (Set of 2)	33022	\$5.95
23	Fuse (20 Amp) 6 per package	33023	\$3.95
24	Handle Grip (Left)	33024	\$3.95
25	Hardware (Assorted Screws, Nuts & Bolts)	33025	\$3.95
26	Head Light Assembly (Lower)	33026	\$39.95
27	Head Light Assembly (Upper-Steering)	33027	\$34.95
28	Horn & Light Switch Assembly	33028	\$12.95
29	Horn (36 Volt)	33029	\$12.95
30	Ignition Cylinder w/ Key	33030	\$12.95
31	Instruction Manual	33031	\$1.95
32	Key (Ignition) (Set of 2)	33032	\$5.95
33	Key (Luggage Rack) (Set of 2)	33033	\$5.95
34	Kickstand	33034	\$24.95
35	Kickstand Spring	33035	\$1.95
36	Kickstand Stop	33036	\$1.95
37	Pedal (Left)	33037	\$5.95
38	Pedal (Right)	33038	\$5.95
39	Pedal Crank Arm (Left)	33039	\$9.95
40	Pedal Crank Arm (Right)	33040	\$9.95
41	Rearview Mirrors (SOLD SEPARATELY)	33041	\$9.95
42	Reflector Red (Rear)	33042	\$2.95
43	Reflectors Amber (Front Left & Front Right)	33043	\$5.95
44	Relay (36 Volt)	33044	\$12.95
45	Seat (Black)	33045	\$29.95
46	Shocks (Rear Left & Rear Right) (Set of 2)	33046	\$29.95
47	Side Skirt (Left) - Red	33082	\$24.95
47	Side Skirt (Left) - Black	33083	\$24.95
47	Side Skirt (Left) - Gold	33084	\$24.95
47	Side Skirt (Left) - White	33085	\$24.95
47	Side Skirt (Left) - Blue	33086	\$24.95
48	Side Skirt (Right) - Red	33087	\$24.95
48	Side Skirt (Right) - Black	33088	\$25.95
48	Side Skirt (Right) -Gold	33089	\$26.95
48	Side Skirt (Right) White	33090	\$27.95
48	Side Skirt (Right) -Blue	33091	\$28.95
49	Sprocket Shaft Assembly	33049	\$29.95
50	Tail Light Assembly (36 Volt)	33050	\$19.95
51	Throttle with Cable & Grip Assembly	33051	\$19.95
52	Tire Tube (Front / Rear)	33052	\$9.95
53	Tires (Front / Rear)	33053	\$19.95
54	Tool Kit	33054	\$12.95
55	Wheel (Front)	33055	\$29.95
56	Wheel Bearings (Front)	33056	\$9.95
57	Wheel w/ Motor Assembly (Rear)	33057	\$89.95
58	Wiring Harness (36 Volt)	33058	\$24.94

30 Day Limited Warranty

Electra Accessories, Inc. ("Electra" the distributor) warrants to the original retail purchaser ("you") that the Electra product for which this warranty has been issued is free from defects in material and workmanship for 30 days from the date of original retail purchase. This warranty is not transferable to a subsequent purchaser. Electra's sole obligation under this warranty is to repair or replace the product, at Electra's option. Electra must be notified in writing of any claim under this warranty within 15 days of any claimed lack of conformity of the product.

Warranty Limitations

The duration of any implied warranty or condition, of merchantability, fitness for a particular purpose, or otherwise, on this product shall be limited to the duration of the express warranty set forth above. In no event shall Electra be liable for any loss, inconvenience or damage, whether direct, incidental, consequential or otherwise, resulting from breach of any express or implied warranty or condition, of merchantability, fitness for a particular purpose, or otherwise with respect to this product, except as set forth herein. Some states or countries do not allow limitation on how long an implied warranty lasts and some do not allow exclusions or limitations of incidental or consequential damages, so the above limitations or exclusions may not apply to you. This warranty gives you specific legal rights, and you may also have other rights, which may vary, from location to location. This warranty will be interpreted pursuant to the laws of the United States. The original English language version/meaning of this warranty controls over all translations and Electra is not responsible for any errors in translation of this warranty or any product instructions. This warranty is not intended to confer any additional legal, jurisdictional or warranty rights to you other than those set forth herein or required by law. If any portion of this warranty is held to be invalid or unenforceable for any reason, such finding will not invalidate any other provision. For products purchased in countries other than the United States please contact Electra's authorized distributor in that respective country.

WARRANTY INFO

Warranty Service Options

To obtain service under this warranty you must Call our Toll-Free Number at 1-888-467-1234 M-F 10am - 9pm EST for Customer Service/Technical Support on your Electra Product BEFORE returning your Electra Product back to the place of purchase. If you return your Electra Product for warranty service you must obtain a return authorization number by calling Electra at 1-888-467-1234 M-F 10am - 9pm EST. Send your Electra product (with the return authorization number on the outside of the shipping container and affixed to the product), together with the retail seller's original receipt or other satisfactory proof of the date of purchase to:

Electra Accessories Inc.
2 Corporate Drive Cranbury, New Jersey 08512 USA
www.electraUSA.com / CustomerServiceNJ@ElectraUSA.com

THE ELECTRA PRODUCT MUST BE RETURNED IN ITS ORIGINAL BOX, ALONG WITH ALL KEYS, CHARGER, MIRRORS & LOCKS, FLOOR MATS, AND ANY OTHER ACCESSORIES THAT CAME WITH YOUR UNIT. DUE TO TRANSPORTATION AND RECLAMATION ISSUES, IF THE ELECTRA PRODUCT IS NOT IN THE ORIGINAL PACKAGE IT MAY NOT BE RETURNED UNDER ANY CIRCUMSTANCES.

Any postage, insurance or other shipping costs incurred in sending your Electra product for service under either option above is your responsibility. Electra will not be responsible for products lost or damaged in shipping.

For products purchased in countries other than the United States please contact Electra's authorized distributor in the country where the product was purchased. They can be found on our website at www.electraUSA.com

Warranty Exclusions are listed below:

- Retailers and sellers of Electra products are not authorized to modify this warranty in any way. It is your responsibility to regularly examine the product to determine the need for normal service or replacement. This warranty does not cover the following:
- Products that have been modified, neglected or poorly maintained, used for commercial purposes, misused or abused or involved in accidents.
- Damage occurring during shipment of the products (such claims must be presented directly to the shipper).
- Damage to products resulting from improper assembly or repair, the use or installation of parts or accessories not compatible with the original intended use of the product, or the failure to follow the product warnings and usage instructions.
- Damage or deterioration to the surface finish, aesthetics or appearance of the product.
- The labor required to remove and/or re-fit and re-adjust the item covered by this warranty.
- Normal wear to the product.
- Any products for which the consumer does not follow the warranty procedures outlined above.

For the current version of this warranty please visit our website at www.electraUSA.com

(© 8/27/04 Electra Accessories, Inc.)

RETURN POLICY

10 DAY RETURN/EXCHANGE POLICY

THIS WRITTEN POLICY SUPERCEDES ANY OTHER PREVIOUS POLICY, WRITTEN OR IMPLIED. THIS WARRANTY IS TO BE POSTED AT THE STORE LEVEL IN PLAIN SIGHT OF THE CONSUMER.

ALL ELECTRA ACCESSORIES PRODUCTS PURCHASED AT RETAIL AFTER JUNE 30, 2004 ARE COVERED UNDER THIS 10 DAY RETURN POLICY

ALL ELECTRA ACCESSORIES PRODUCTS ARE EXCHANGEABLE OR RETURNABLE FOR ANY REASON TO THE RETAIL POINT OF PURCHASE, IF ACCOMPANIED BY A STORE RECEIPT, FOR A PERIOD OF TEN (10) DAYS FROM THE DATE OF PURCHASE. TO BE ELIGIBLE FOR RETURN OR EXCHANGE, ALL ELECTRA ACCESSORIES PRODUCTS MUST BE IN LIKE NEW CONDITION, IN THE ORIGINAL BOX, ALONG WITH ALL ACCESSORIES THAT INCLUDE, BUT IS NOT LIMITED TO, KEYS, MIRRORS, TOOL KITS, LOCKS, MANUALS, FUSES, CHARGERS, ETC. ALL RACER PRODUCTS MUST HAVE THE KEYS REMOVED FROM THE KEY SLOT AND ATTACHED WITH A ZIP TIE TO THE HANDLE BARS, THE FUSE REMOVED, AND THE BATTERY DISCONNECTED EITHER BY THE QUICK DISCONNECT, OR BY REMOVING THE BATTERY LEADS AND COVERING THE TERMINALS WITH TAPE. IN COMPLIANCE WITH FEDERAL REGULATIONS, IF THE RETURNED UNIT IS GAS, THE FUEL MUST BE DRAINED FROM THE TANK, AND THE FUEL LINES IN SUCH A WAY AS TO PROTECT THE ENVIRONMENT FROM CONTAMINATING SOIL OR WATER RESOURCES. GAS RACER PRODUCTS THAT ARE RETURNED TO THE RETAIL POINT OF PURCHASE WITH FUEL IN THE TANK, OR IN THE FUEL LINES, ARE NOT ELIGIBLE FOR RETURN OR EXCHANGE.

DURING THE TEN (10) DAY RETURN/EXCHANGE PERIOD, ALL ELECTRA ACCESSORIES PRODUCTS ARE ALSO COVERED BY A THIRTY (30) DAY WARRANTY ON PARTS. THE WARRANTY DOES NOT COVER THE COST OF LABOR ON ANY PRODUCT FOR ANY REASON. THE CURRENT 30 DAY WARRANTY IS AVAILABLE ON THE INTERNET BY VISITING WWW.ELECTRAUSA.COM OR BY CALLING THE ELECTRA ACCESSORIES TOLL FREE CUSTOMER SUPPORT NUMBER AT (888) 467-1234.

AFTER THE THIRTY (30) DAY WARRANTY, REPLACEMENT PARTS MAY BE PURCHASED ON THE INTERNET BY VISITING WWW.ELECTRAUSA.COM OR BY CALLING THE ELECTRA ACCESSORIES TOLL FREE CUSTOMER SUPPORT NUMBER AT (888) 467-1234. CUSTOMERS ARE RESPONSIBLE FOR THE COST OF THE PART(S) NEEDED, AND ANY APPLICABLE UPS, FED EX, OR USPS SHIPPING CHARGES THAT APPLY. .

ELECTRA OR THE RETAIL STORE MAY REFUSE ANY RETURN OR EXCHANGE IF THE PRODUCT IN QUESTION APPEARS TO HAVE BEEN NEGLECTED BY THE OWNER OR IF THE PRODUCT HAS BEEN DAMAGED OR IF THE CONSUMER FAILED TO COMPLY WITH THE WRITTEN INSTRUCTION MANUAL, THIS 10 DAY RETURN POLICY OR THE ELECTRA 30 DAY WARRANTY TERMS. RETAILERS AND SELLERS OF ELECTRA PRODUCTS ARE NOT AUTHORIZED TO MODIFY THIS RETURN/EXCHANGE POLICY OR WARRANTY IN ANY WAY.

