

# STOP!

## Service Bulletin - MX500 Front Wheel Installation

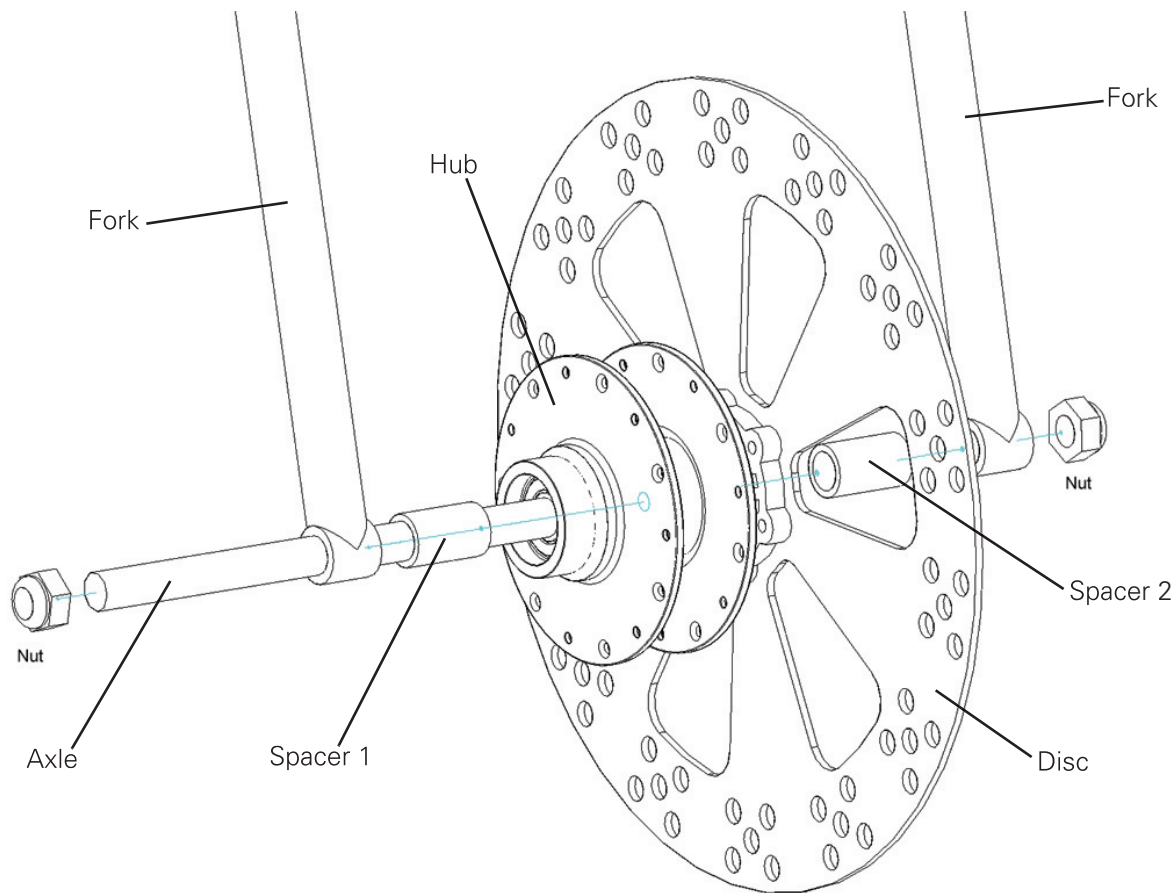

### PROCEDURE UPDATE:

- 1** Hold the front wheel approximately centered in the fork, taking care to position the disc into the brake caliper assembly.
- 2** With "spacer 1" ready, slide the axle into the fork and align "spacer 1" (the long spacer, if spacers are unequal length) with the axle and between the fork and hub. Further slide the axle into the fork and spacer and through the hub until it barely protrudes from the disc side of the hub.
- 3** Position "spacer 2" between the disc side of the hub and the fork and then slide the axle until the thread protrudes enough to engage the axle nut.
- 4** Install and tighten the axle nuts so there is an even tread engagement on both sides.

**Need Help?** Visit our website for additional instructions at [www.razor.com](http://www.razor.com) or call toll-free at 866-467-2967 Monday - Friday 8:00am - 5:00pm Pacific Time.

09/16/05