

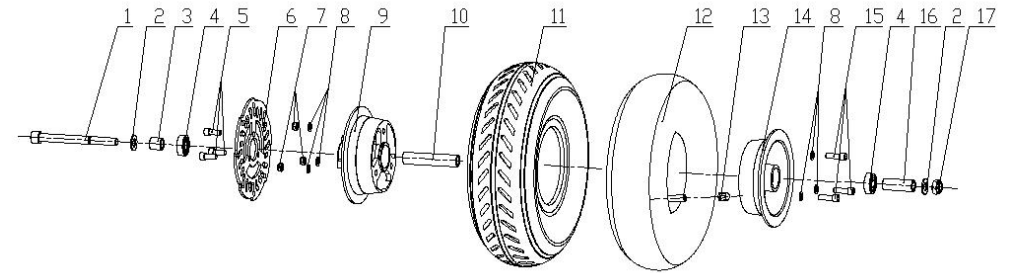

Scooter Parts Information

Model No. : MS-SS501

PART-A front wheel



Item	Name	Specification/Size	Qty
A-1	bolt	M10×170	1
A-2	washer	Φ20×Φ10.5×1.5	2
A-3	spacer	Φ15×Φ10.1×15	1
A-4	bearing	6000	2
A-5	bolt	M6×15	3
A-6	Disk, brake	Φ130	1
A-7	locknut	M6	3
A-8	washer	Φ11×Φ6.4×1	3
A-9	hub, wheel		1
A-10	spacer	Φ15×Φ10.1×72.8	1
A-11	tire	10in	1
A-12	tube		1
A-13	inflation spot		1
A-14	Hub, wheel		1
A-15	bolt	M6×25	3
A-16	spacer	Φ15×Φ10.1×40	1
A-17	bolt	M10	1

PART-B rear wheel

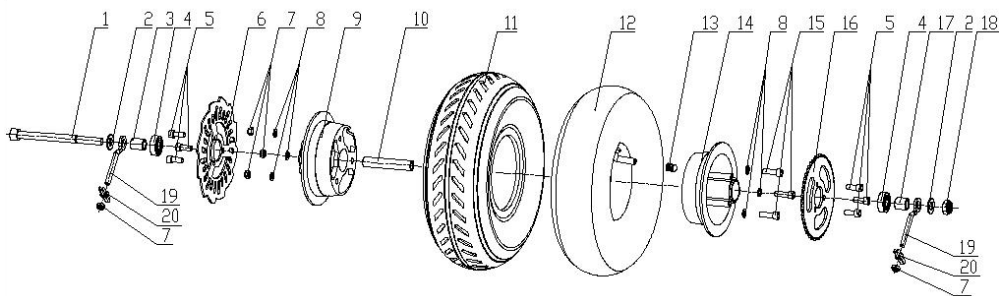

Item	Name	specification/size	QTY
B-1	bolt	M10×170	1
B-2	washer	Φ20×Φ10.5×1.5	2
B-3	spacer	Φ15×Φ10.1×17.5	1
B-4	bearing	6000	2
B-5	bolt	M6×15	6
B-6	Disc brake	Φ140	1
B-7	locknut	M6	5
B-8	washer	Φ11×Φ6.4×1	6
B-9	Hub, wheel		1
B-10	spacer	Φ15×Φ10.1×94.5	1
B-11	tire	10in	1
B-12	tube		1
B-13	Inflation spot		1
B-14	Hub, wheel		1
B-15	bolt	M6×25	3
B-16	Chain sprocket	55th	1
B-17	spacer	Φ15×Φ10.1×15.5	1
B-18	Nut, locknut	M10	1
B-19	Tensioner set		2
B-20	Tensioner set		2

PART-C Rear part

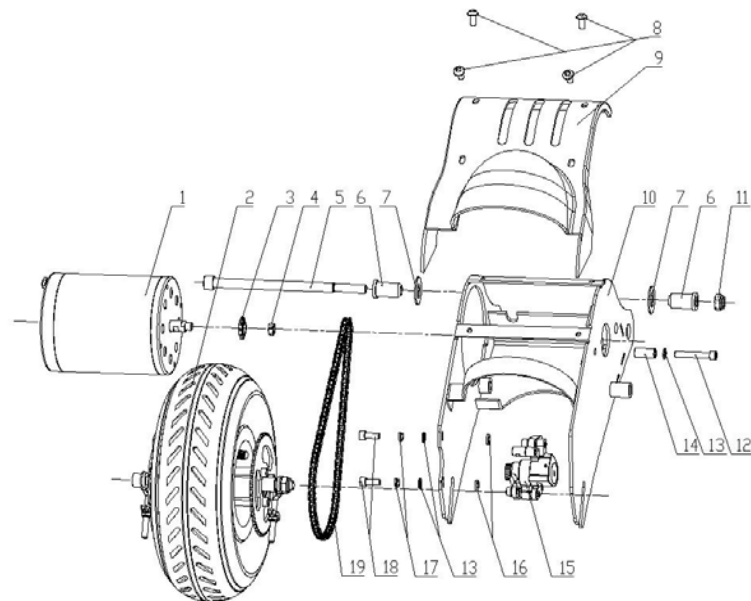

Item	Name	specification/size	QTY
C-1	motor	800W	1
C-2	Rear Wheel set		1
C-3	Small sprocket	11th	1
C-4	nut	M6	1
C-5	bolt	M10×170	1
C-6	spacer	Φ16×Φ10×30	2
C-7	washer	Φ16×Φ30×1.5	2
C-8	bolt	M6×12	4
C-9	mudguard		1
C-10	frame		1
C-11	Nut, locknut	M10	1
C-12	bolt	M6×40	1
C-13	washer	Φ11×Φ6.4×1	3
C-14	Spacer for motor	Φ12×Φ7×25	1
C-15	caliper		1
C-16	washer	Φ11×Φ6.4×2	2
C-17	Spring, washer		2
C-18	bolt	M6×16	2
C-19	chain	96kts	1

Handler Bar

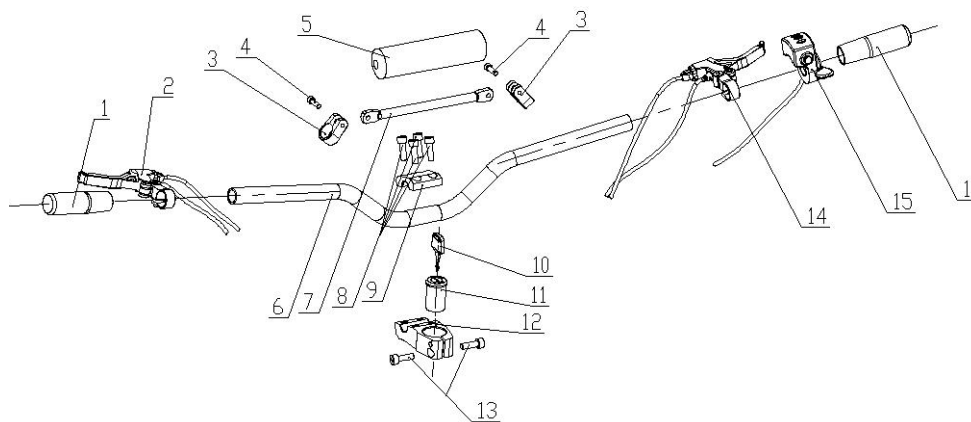

Item	name	specification/size	QTY
D-1	grip		2
D-2	Rear brake lever		1
D-3	nut		2
D-4	bolt	M6×20	2
D-5	Spongy sticker		1
D-6	Handlebar		1
D-7	Handlebar		1
D-8	bolt	M8×20	4
D-9	Stem, steering		1
D-10	Key		1
D-11	Key switch		1
D-12	Stem, steering		1
D-13	bolt	M8×25	2
D-14	Front brake lever		1
D-15	throttle		1

PART-E front suspension

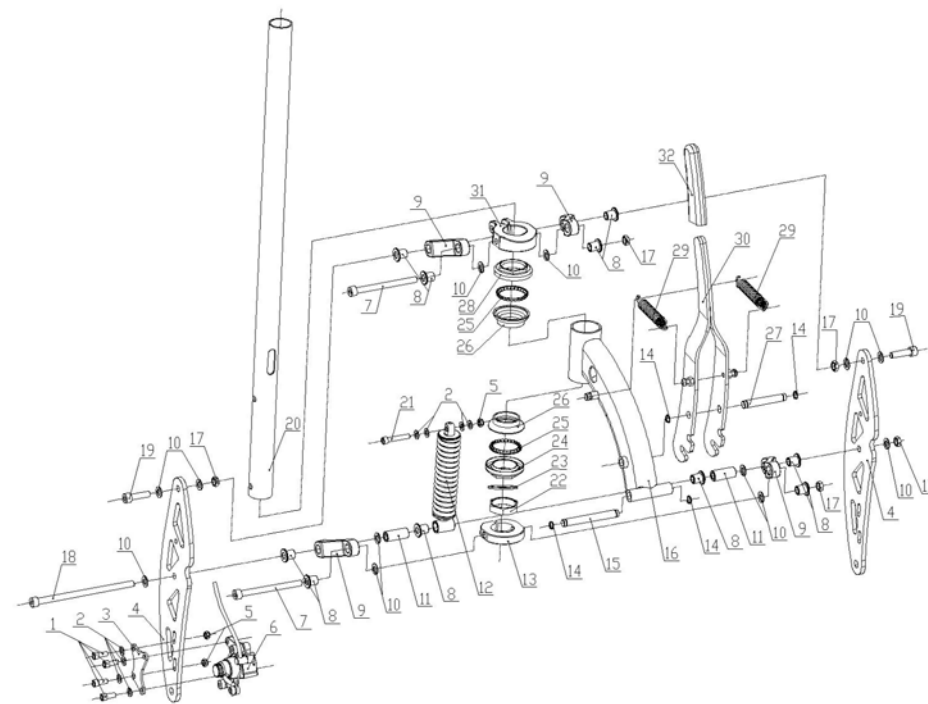

Item	Name	specification/size	QTY
E-1	screw		1
E-2	washer		
E-3	Caliper support		5
E-4	fork		2
E-5	nut		2
E-6	caliper		1
E-7	bolt		1
E-8	screw		1
E-9	rocker		1
E-10	washer		1
E-11	spacer		1
E-12	shock		1
E-13	Locking ring		1
E-14	Snap spring		1
E-15	Neck support		2
E-16	neck		4
E-17	Locknut		1

E-18	bolt		2
E-19	bolt		1
E-20	Handle pipe		2
E-21	bolt		1
E-22	Heap cut set		1
E-23	Heap cut set		1
E-24	Heap cut set		1
E-25	Heap cut set		1
E-26	Heap cut set		1
E-27	bolt		1
E-28	Heap cut set		1
E-29	spring		4
E-30	Folding handle		2
E-31	bolt		1
E-32	Lock ring		1
E-33	rubber		1
E-34			1

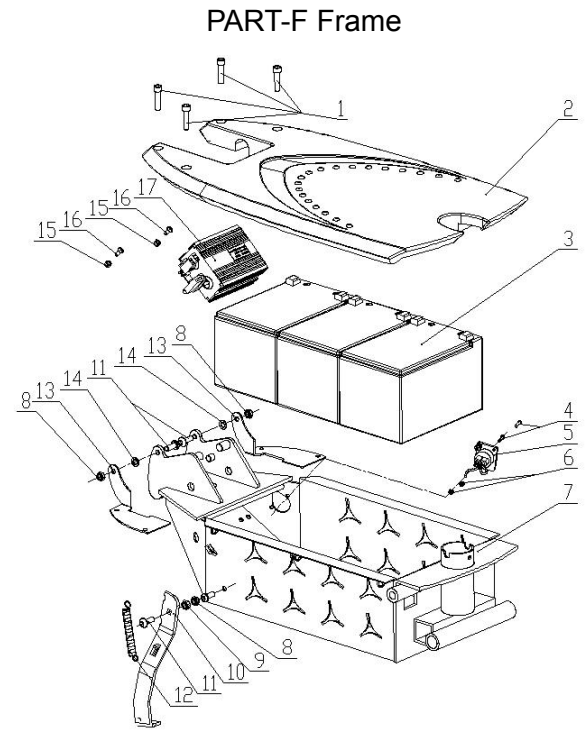

Item	Name	specification/size	QTY
F-1	bolt	M6×25	4
F-2	Foot deck		1
F-3	battery	12V/12Ah	3
F-4	bolt	M3×13	2
F-5	Charger spot		1
F-6	nut	M3	2
F-7	Battery box		1
F-8	locknut	M6	1
F-9	nut	M6	1
F-10	Kick stand		1
F-11	bolt	M6×16	3
F-12	spring		1
F-13	Left/right connect		2
F-14	washer	Φ11×Φ6.4×1	2
F-15	locknut	M4	2
F-16	bolt	M4×10	2
F-17	controller	30A/800W	1

PART-G Rear shock

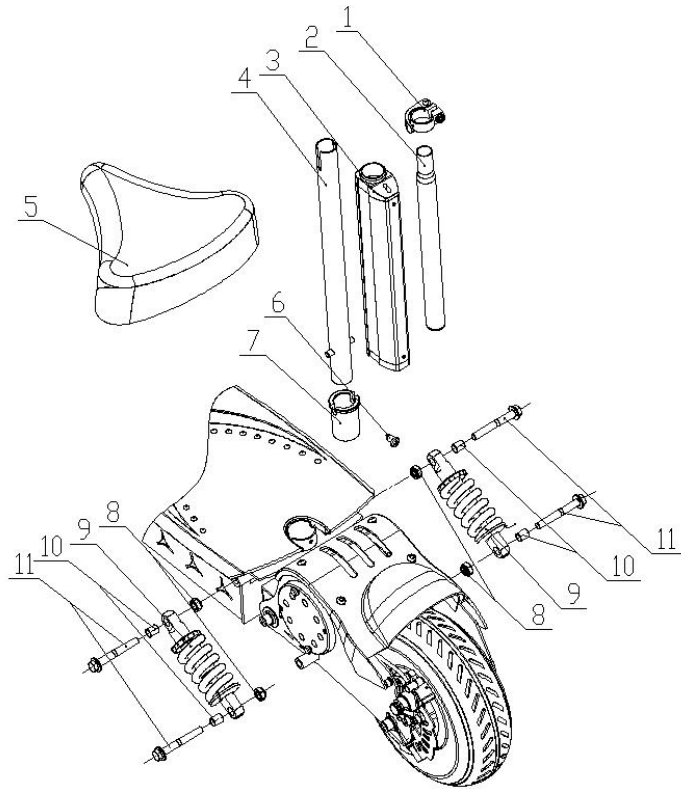

Item	Name	specification/size	QTY
G-1	Seat clip		1
G-2	Seat pole		1
G-3	Seat pole, cover		1
G-4	Seat pole		1
G-5	seat		1
G-6	bolt	M3×6	1
G-7	Seat bush		1
G-8	locknut	M10	4
G-9	Rear shock		2
G-10	spacer	Φ12×Φ10×14	4
G-11	bolt	M10×70	4